

Intelligent Drivesystems, Worldwide Services

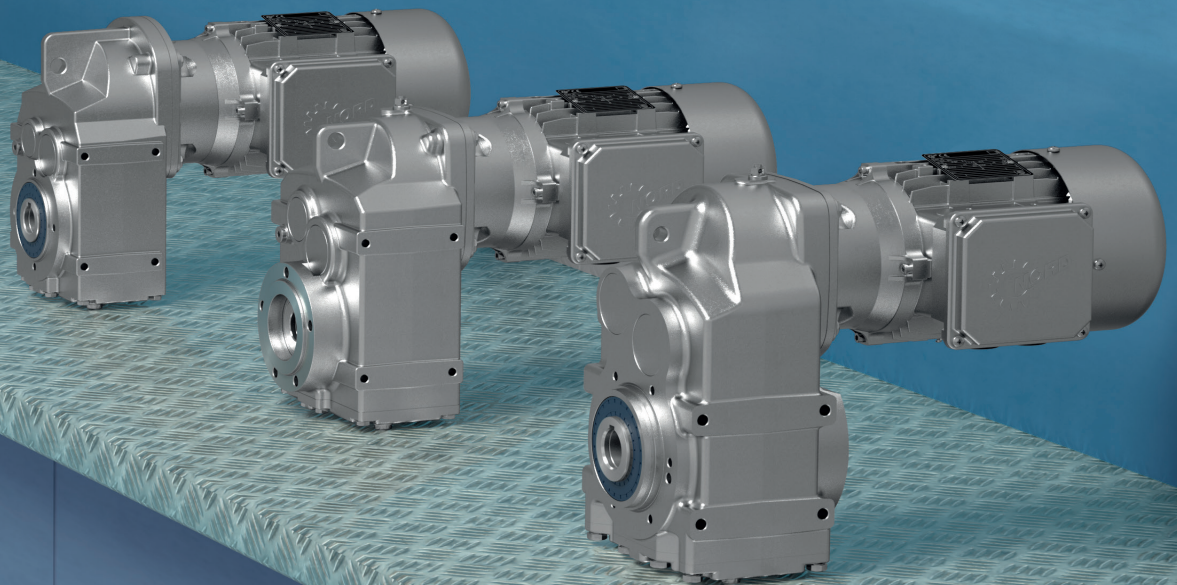

DE

# PRODUKTINFORMATION

Flachgetriebe

IE3

T160-0009

**NORD**<sup>®</sup>  
DRIVESYSTEMS

# Inhaltsübersicht

---

## NETZFREQUENZ **50** HZ + **METRISCHE DARSTELLUNG**

LEISTUNGS- UND DREHZAHLÜBERSICHTEN .....	1
LEISTUNGS- UND ÜBERSETZUNGSÜBERSICHTEN .....	10
MASSBILDER .....	14

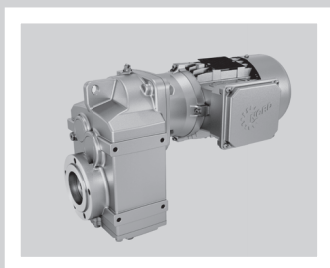

DRIVESYSTEMS

[www.nord.com](http://www.nord.com)

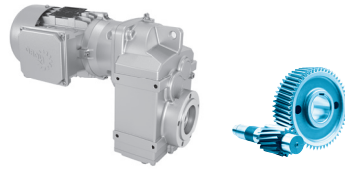

$P_1$ [kW]	$n_2$ [min <sup>-1</sup> ]	$M_2$ [Nm]	$f_B$	$i_{ges}$	$F_R$ [kN]	$F_A$ [kN]	$F_{RVL}$ [kN]	$F_{AVL}$ [kN]	Type	kg
<b>0,12</b>	7,6	150	2,7	179,22	6,6	7,2	9,2	7,2	<b>SK 1382.1 - 63 SP/4</b>	18
	5,6	205	2,0	245,16	6,3	7,2	9,0	7,2		
	4,8	240	1,7	287,37	6,1	7,2	8,9	7,2		
	4,5	255	1,4	304,47	6,0	7,2	8,8	7,2		
	3,8	299	1,2	356,89	5,7	7,2	8,6	7,2		
<b>0,12</b>	26	44,4	4,1	53,03	6,7	5,0			<b>SK 0282.1 - 63 SP/4</b>	12
	21	55,8	3,6	66,66	7,0	5,0				
	18	63,3	3,2	75,69	7,0	5,0				
	15	77,4	2,6	92,51	7,0	5,0				
	13	86,9	2,3	103,89	6,9	5,0				
	12	92,8	2,2	110,96	6,9	5,0				
	11	106	1,9	126,98	6,9	5,0				
	9,7	118	1,7	140,98	6,9	5,0				
	8,5	135	1,5	161,34	6,8	5,0				
	7,2	159	1,3	190,64	6,7	5,0				
	6,8	169	1,2	201,65	6,7	5,0				
	6	191	1,0	228,16	6,6	5,0				
	5,5	207	0,9	247,02	6,5	5,0				
<b>0,12</b>	43	26,6	4,9	31,80	4,9	5,8			<b>SK 0182.1 - 63 SP/4</b>	10
	40	28,5	4,6	34,13	5,0	5,8				
	35	32,3	4,0	38,61	5,0	5,8				
	31	36,8	3,5	43,98	5,0	5,8				
	28	41,4	3,1	49,46	5,0	5,8				
	23	48,9	2,7	58,43	5,0	5,8				
	21	53,6	2,1	64,03	5,0	5,8				
	18	62,5	1,8	74,73	5,0	5,8				
	16	72,6	1,5	86,80	5,0	5,8				
	14	79,6	1,4	95,13	5,0	5,8				
	12	92,9	1,2	111,02	4,9	5,8				
	10	110	1,0	131,56	4,8	5,8				
	9,3	124	0,9	147,93	4,8	5,8				
	8,9	128	0,9	153,54	4,7	5,8				
<b>0,18</b>	20	85	4,7	68,50	6,8	7,2	9,4	7,2	<b>SK 1382.1 - 63 LP/4</b>	19
	7,7	222	1,8	179,22	6,2	7,2	9,0	7,2		
	5,6	304	1,3	245,16	5,6	7,2	8,6	7,2		
	4,8	357	1,1	287,37	5,1	7,2	8,2	7,2		
	4,5	378	1,0	304,47	4,8	7,2	8,1	7,2		
	3,9	443	0,8	356,89	1,7	7,2	7,5	7,2		

**0,18 kW**  
**0,25 kW**

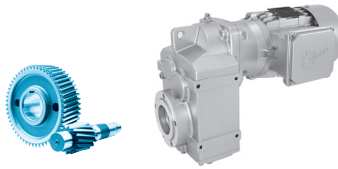

$P_1$ [kW]	$n_2$ [min <sup>-1</sup> ]	$M_2$ [Nm]	$f_B$	$i_{ges}$	$F_R$ [kN]	$F_A$ [kN]	$F_{RVL}$ [kN]	$F_{AVL}$ [kN]	Type	kg
<b>0,18</b>	41	41,5	4,8	33,44	5,7	5,0			<b>SK 0282.1 - 63 LP/4</b>	13
	36	47,3	4,2	38,14	5,9	5,0				
	32	54,3	3,7	43,78	6,2	5,0				
	26	65,8	2,7	53,03	6,5	5,0				
	21	82,7	2,4	66,66	6,9	5,0				
	18	93,9	2,1	75,69	6,9	5,0				
	15	115	1,7	92,51	6,9	5,0				
	13	129	1,6	103,89	6,8	5,0				
	12	138	1,5	110,96	6,8	5,0				
	11	158	1,3	126,98	6,7	5,0				
	9,8	175	1,1	140,98	6,7	5,0				
	8,6	200	1,0	161,34	6,5	5,0				
	7,3	237	0,8	190,64	6,3	5,0				
	6,9	250	0,8	201,65	6,2	5,0				
<b>0,18</b>	70	24,6	4,9	19,83	4,2	5,8			<b>SK 0182.1 - 63 LP/4</b>	11
	62	27,8	4,3	22,43	4,3	5,8				
	56	30,6	4,2	24,68	4,4	5,8				
	50	34,6	3,8	27,92	4,6	5,8				
	44	39,5	3,3	31,80	4,8	5,8				
	41	42,4	3,1	34,13	4,9	5,8				
	36	47,9	2,7	38,61	5,0	5,8				
	31	54,6	2,4	43,98	5,0	5,8				
	28	61,4	2,1	49,46	5,0	5,8				
	24	72,5	1,8	58,43	5,0	5,8				
	22	79,5	1,4	64,03	5,0	5,8				
	19	92,7	1,2	74,73	4,9	5,8				
	16	108	1,0	86,80	4,9	5,8				
	15	118	0,9	95,13	4,8	5,8				
12	138	0,8	111,02	4,7	5,8					
<b>0,25</b>	28	86,7	4,6	51,41	6,8	7,2	9,4	7,2	<b>SK 1382.1 - 71 SP/4</b>	21
	26	91,6	4,4	54,32	6,7	7,2	9,3	7,2		
	23	102	3,9	60,26	6,7	7,2	9,3	7,2		
	21	116	3,5	68,50	6,7	7,2	9,3	7,2		
	10	229	1,7	135,72	6,2	7,2	8,9	7,2		
	8,9	268	1,5	159,09	5,9	7,2	8,8	7,2		
	7,9	302	1,3	179,22	5,6	7,2	8,6	7,2		
	6,5	367	1,1	217,62	4,9	7,2	8,1	7,2		
	5,8	414	1,0	245,16	3,6	7,2	7,8	7,2		
	4,9	485	0,8	287,37	-	7,2	7,0	7,2		



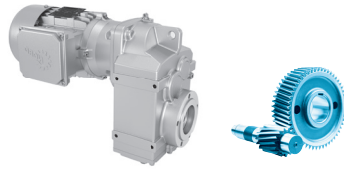

P <sub>1</sub> [kW]	n <sub>2</sub> [min <sup>-1</sup> ]	M <sub>2</sub> [Nm]	f <sub>B</sub>	i <sub>ges</sub>	F <sub>R</sub> [kN]	F <sub>A</sub> [kN]	F <sub>R VL</sub> [kN]	F <sub>A VL</sub> [kN]	Type	kg
<b>0,25</b>	54	44,4	4,5	26,32	5,2	5,0			<b>SK 0282.1 - 71 SP/4</b>	14
	48	49,9	4,0	29,56	5,4	5,0				
	42	56,4	3,5	33,44	5,5	5,0				
	37	64,3	3,1	38,14	5,8	5,0				
	32	73,9	2,7	43,78	6,0	5,0				
	27	89,5	2,0	53,03	6,2	5,0				
	21	112	1,8	66,66	6,6	5,0				
	19	128	1,6	75,69	6,8	5,0				
	15	156	1,3	92,51	6,7	5,0				
	14	175	1,1	103,89	6,6	5,0				
	13	187	1,1	110,96	6,6	5,0				
	11	214	0,9	126,98	6,5	5,0				
	10	238	0,8	140,98	6,3	5,0				
<b>0,25</b>	87	27,4	4,7	16,24	3,8	5,8			<b>SK 0182.1 - 71 SP/4</b>	12
	71	33,5	3,6	19,83	4,0	5,8				
	63	37,8	3,2	22,43	4,2	5,8				
	57	41,6	3,1	24,68	4,3	5,8				
	51	47,1	2,8	27,92	4,4	5,8				
	44	53,7	2,4	31,80	4,6	5,8				
	41	57,6	2,3	34,13	4,7	5,8				
	37	65,1	2,0	38,61	4,8	5,8				
	32	74,2	1,8	43,98	5,0	5,8				
	29	83,4	1,6	49,46	5,0	5,8				
	24	98,6	1,3	58,43	4,9	5,8				
	22	108	1,0	64,03	4,9	5,8				
	19	126	0,9	74,73	4,7	5,8				
16	146	0,8	86,80	4,6	5,8					
<b>0,37</b>	43	83	4,8	32,99	6,1	7,2	9,4	7,2	<b>SK 1382.1 - 71 LP/4</b>	22
	36	97,2	4,1	38,67	6,4	7,2	9,3	7,2		
	32	111	3,6	44,19	6,6	7,2	9,3	7,2		
	27	129	3,1	51,41	6,6	7,2	9,3	7,2		
	26	137	2,9	54,32	6,6	7,2	9,3	7,2		
	23	152	2,6	60,26	6,6	7,2	9,2	7,2		
	21	172	2,3	68,50	6,5	7,2	9,2	7,2		
	10	341	1,2	135,72	5,2	7,2	8,3	7,2		
	8,8	400	1,0	159,09	4,1	7,2	7,9	7,2		
	7,8	451	0,9	179,22	0,4	7,2	7,4	7,2		

**0,37 kW**  
**0,55 kW**

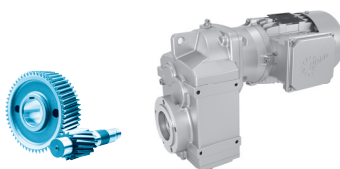

$P_1$ [kW]	$n_2$ [min <sup>-1</sup> ]	$M_2$ [Nm]	$f_B$	$i_{ges}$	$F_R$ [kN]	$F_A$ [kN]	$F_{RVL}$ [kN]	$F_{AVL}$ [kN]	Type	kg
<b>0,37</b>	87	40,5	4,9	16,12	4,4	5,0			<b>SK 0282.1 - 71 LP/4</b>	15
	77	45,9	4,4	18,24	4,5	5,0				
	74	47,7	4,2	18,96	4,6	5,0				
	65	54,2	3,7	21,53	4,8	5,0				
	53	66,2	3,0	26,32	5,0	5,0				
	48	74,3	2,7	29,56	5,2	5,0				
	42	84,1	2,4	33,44	5,3	5,0				
	37	95,9	2,1	38,14	5,5	5,0				
	32	110	1,8	43,78	5,7	5,0				
	26	133	1,3	53,03	5,9	5,0				
	21	168	1,2	66,66	6,2	5,0				
	19	190	1,1	75,69	6,3	5,0				
	15	233	0,9	92,51	6,3	5,0				
	14	261	0,8	103,89	6,2	5,0				
<b>0,37</b>	123	28,8	4,5	11,45	3,4	5,8			<b>SK 0182.1 - 71 LP/4</b>	13
	108	32,8	4,0	13,05	3,5	5,8				
	99	35,8	3,6	14,25	3,6	5,8				
	87	40,8	3,2	16,24	3,7	5,8				
	71	49,9	2,4	19,83	3,9	5,8				
	63	56,4	2,1	22,43	4,0	5,8				
	57	62,1	2,1	24,68	4,1	5,8				
	50	70,2	1,9	27,92	4,2	5,8				
	44	80	1,6	31,80	4,4	5,8				
	41	85,8	1,5	34,13	4,4	5,8				
	36	97,1	1,3	38,61	4,6	5,8				
	32	111	1,2	43,98	4,7	5,8				
	28	124	1,0	49,46	4,8	5,8				
	24	147	0,9	58,43	4,6	5,8				
<b>0,55</b>	50	106	3,8	28,54	5,6	7,2	9,3	7,2	<b>SK 1382.1 - 80 SP/4</b>	24
	43	122	3,3	32,99	5,8	7,2	9,3	7,2		
	37	143	2,8	38,67	6,0	7,2	9,2	7,2		
	32	163	2,4	44,19	6,2	7,2	9,2	7,2		
	28	190	2,1	51,41	6,4	7,2	9,1	7,2		
	26	201	2,0	54,32	6,3	7,2	9,1	7,2		
	24	223	1,8	60,26	6,2	7,2	9,0	7,2		
	21	253	1,6	68,50	6,0	7,2	8,8	7,2		
	17	307	1,3	82,94	5,6	7,2	8,5	7,2		
	15	360	1,1	97,22	5,0	7,2	8,2	7,2		
	14	383	1,0	103,68	4,7	7,2	8,0	7,2		
	12	449	0,9	121,52	0,8	7,2	7,4	7,2		
	10	502	0,8	135,72	-	7,2	6,8	7,2		
<b>0,55</b>	58	90,9	4,4	24,57	5,4	7,2	9,3	7,2	<b>SK 1282.1 - 80 SP/4</b>	24

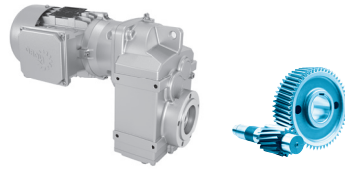

P <sub>1</sub> [kW]	n <sub>2</sub> [min <sup>-1</sup> ]	M <sub>2</sub> [Nm]	f <sub>B</sub>	i <sub>ges</sub>	F <sub>R</sub> [kN]	F <sub>A</sub> [kN]	F <sub>R VL</sub> [kN]	F <sub>A VL</sub> [kN]	Type	kg
<b>0,55</b>	126	41,8	4,8	11,30	3,8	5,0			<b>SK 0282.1 - 80 SP/4</b>	18
	111	47,3	4,2	12,78	3,9	5,0				
	99	53,1	3,8	14,36	4,1	5,0				
	88	59,6	3,4	16,12	4,2	5,0				
	78	67,5	3,0	18,24	4,4	5,0				
	75	70,1	2,9	18,96	4,4	5,0				
	66	79,6	2,5	21,53	4,5	5,0				
	54	97,3	2,1	26,32	4,7	5,0				
	48	109	1,8	29,56	4,9	5,0				
	42	124	1,6	33,44	5,0	5,0				
	37	141	1,4	38,14	5,1	5,0				
	32	162	1,2	43,78	5,2	5,0				
	27	196	0,9	53,03	5,3	5,0				
	21	247	0,8	66,66	5,5	5,0				
<b>0,55</b>	199	26,4	4,9	7,12	2,8	5,0			<b>SK 0182.1 - 80 SP/4</b>	16
	174	30,3	4,3	8,18	3,0	5,2				
	160	32,8	4,0	8,87	3,0	5,3				
	140	37,4	3,5	10,13	3,1	5,5				
	124	42,4	3,1	11,45	3,2	5,7				
	109	48,3	2,7	13,05	3,3	5,8				
	100	52,7	2,5	14,25	3,4	5,8				
	87	60,1	2,2	16,24	3,5	5,8				
	72	73,3	1,6	19,83	3,7	5,8				
	63	83	1,4	22,43	3,8	5,8				
	58	91,3	1,4	24,68	3,8	5,8				
	51	103	1,3	27,92	3,9	5,8				
	45	118	1,1	31,80	4,0	5,8				
	42	126	1,0	34,13	4,1	5,8				
	37	143	0,9	38,61	4,1	5,8				
	32	163	0,8	43,98	4,2	5,8				
<b>0,75</b>	50	144	2,8	28,54	5,4	7,2	9,2	7,2	<b>SK 1382.1 - 80 LP/4</b>	25
	43	167	2,4	32,99	5,5	7,2	9,2	7,2		
	37	196	2,0	38,67	5,7	7,2	9,1	7,2		
	32	224	1,8	44,19	5,8	7,2	9,0	7,2		
	28	260	1,5	51,41	5,9	7,2	8,8	7,2		
	26	275	1,5	54,32	5,9	7,2	8,7	7,2		
	23	305	1,3	60,26	5,6	7,2	8,6	7,2		
	21	347	1,2	68,50	5,2	7,2	8,3	7,2		
	17	420	1,0	82,94	3,3	7,2	7,7	7,2		
	15	492	0,8	97,22	-	7,2	6,9	7,2		
	14	525	0,8	103,68	-	7,2	6,5	7,2		
<b>0,75</b>	85	84,3	4,7	16,66	4,7	7,2	9,4	7,2	<b>SK 1282.1 - 80 LP/4</b>	24
	72	98,8	4,0	19,52	4,9	7,2	9,3	7,2		
	68	106	3,8	20,96	5,0	7,2	9,3	7,2		
	58	124	3,2	24,57	5,2	7,2	9,3	7,2		

**0,75 kW**  
**1,10 kW**

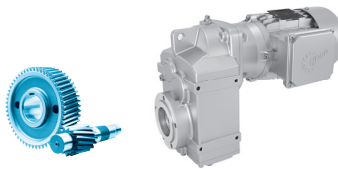

$P_1$ [kW]	$n_2$ [min <sup>-1</sup> ]	$M_2$ [Nm]	$f_B$	$i_{ges}$	$F_R$ [kN]	$F_A$ [kN]	$F_{RVL}$ [kN]	$F_{AVL}$ [kN]	Type	kg
<b>0,75</b>	172	41,7	4,8	8,24	3,4	5,0			<b>SK 0282.1 - 80 LP/4</b>	18
	154	46,4	4,3	9,18	3,5	5,0				
	141	50,9	3,9	10,06	3,6	5,0				
	125	57,2	3,5	11,30	3,7	5,0				
	111	64,7	3,1	12,78	3,8	5,0				
	99	72,7	2,8	14,36	3,9	5,0				
	88	81,6	2,5	16,12	4,0	5,0				
	78	92,3	2,2	18,24	4,2	5,0				
	75	96	2,1	18,96	4,2	5,0				
	66	109	1,8	21,53	4,3	5,0				
	54	133	1,5	26,32	4,5	5,0				
	48	150	1,3	29,56	4,5	5,0				
	42	169	1,2	33,44	4,6	5,0				
	37	193	1,0	38,14	4,7	5,0				
32	222	0,9	43,78	4,8	5,0					
<b>0,75</b>	292	24,5	4,9	4,85	2,5	4,3			<b>SK 0182.1 - 80 LP/4</b>	16
	255	28	4,3	5,54	2,6	4,5				
	227	31,5	4,1	6,23	2,7	4,7				
	199	36,1	3,6	7,12	2,8	4,8				
	173	41,4	3,1	8,18	2,9	5,0				
	160	44,9	2,9	8,87	2,9	5,1				
	140	51,2	2,5	10,13	3,0	5,3				
	124	58	2,2	11,45	3,1	5,4				
	108	66,1	2,0	13,05	3,2	5,6				
	99	72,1	1,8	14,25	3,2	5,7				
	87	82,2	1,6	16,24	3,3	5,8				
	71	100	1,2	19,83	3,4	5,8				
	63	114	1,1	22,43	3,5	5,8				
	57	125	1,0	24,68	3,5	5,8				
	51	141	0,9	27,92	3,6	5,8				
44	161	0,8	31,80	3,6	5,8					
41	173	0,8	34,13	3,6	5,8					
<b>1,10</b>	50	210	1,9	28,54	4,9	7,2	9,0	7,2	<b>SK 1382.1 - 90 SP/4</b>	30
	43	242	1,7	32,99	4,9	7,2	8,9	7,2		
	37	284	1,4	38,67	5,0	7,2	8,7	7,2		
	32	325	1,2	44,19	5,0	7,2	8,4	7,2		
	28	378	1,1	51,41	4,8	7,2	8,1	7,2		
	26	399	1,0	54,32	4,2	7,2	7,9	7,2		
	24	443	0,9	60,26	1,7	7,2	7,5	7,2		
	21	503	0,8	68,50	-	7,2	6,8	7,2		
<b>1,10</b>	131	79,9	5,0	10,88	4,0	6,9	9,4	7,2	<b>SK 1282.1 - 90 SP/4</b>	29
	117	89,5	4,5	12,19	4,1	7,1	9,3	7,2		
	104	101	4,0	13,74	4,3	7,2	9,3	7,2		
	86	122	3,3	16,66	4,4	7,2	9,3	7,2		
	73	143	2,8	19,52	4,6	7,2	9,2	7,2		
	68	154	2,6	20,96	4,6	7,2	9,2	7,2		
	58	180	2,2	24,57	4,8	7,2	9,1	7,2		



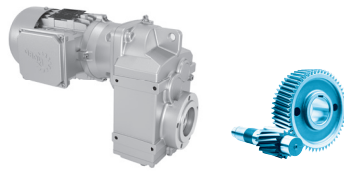

P <sub>1</sub> [kW]	n <sub>2</sub> [min <sup>-1</sup> ]	M <sub>2</sub> [Nm]	f <sub>B</sub>	i <sub>ges</sub>	F <sub>R</sub> [kN]	F <sub>A</sub> [kN]	F <sub>R VL</sub> [kN]	F <sub>A VL</sub> [kN]	Type	kg
1,10	299	35,1	4,6	4,79	2,8	5,0			SK 0282.1 - 90 SP/4	23
	261	40,2	4,0	5,47	2,9	5,0				
	223	47,1	3,8	6,43	3,0	5,0				
	210	50,1	4,0	6,82	3,1	5,0				
	174	60,5	3,3	8,24	3,2	5,0				
	156	67,3	3,0	9,18	3,3	5,0				
	142	73,9	2,7	10,06	3,4	5,0				
	127	83	2,4	11,30	3,4	5,0				
	112	93,9	2,1	12,78	3,5	5,0				
	100	105	1,9	14,36	3,7	5,0				
	89	118	1,7	16,12	3,7	5,0				
	78	134	1,5	18,24	3,8	5,0				
	75	139	1,4	18,96	3,8	5,0				
	66	158	1,3	21,53	3,9	5,0				
	54	193	1,0	26,32	3,9	5,0				
1,50	50	289	1,4	28,54	4,3	7,2	8,6	7,2	SK 1382.1 - 90 LP/4	31
	43	334	1,2	32,99	4,3	7,2	8,4	7,2		
	37	391	1,0	38,67	4,3	7,2	7,9	7,2		
	32	447	0,9	44,19	1,1	7,2	7,4	7,2		
	28	520	0,8	51,41	-	7,2	6,6	7,2		
1,50	271	52,9	4,8	5,22	3,2	5,2	9,4	7,2	SK 1282.1 - 90 LP/4	31
	222	64,5	4,4	6,38	3,4	5,8	9,4	7,2		
	189	75,6	4,2	7,47	3,5	6,0	9,4	7,2		
	172	83,5	3,8	8,25	3,6	6,2	9,4	7,2		
	146	97,9	3,7	9,67	3,8	6,4	9,3	7,2		
	130	110	3,6	10,88	3,8	6,6	9,3	7,2		
	116	123	3,2	12,19	3,9	6,7	9,3	7,2		
	103	139	2,9	13,74	4,0	6,9	9,2	7,2		
	85	169	2,4	16,66	4,1	7,1	9,2	7,2		
	72	198	2,0	19,52	4,2	7,2	9,1	7,2		
	68	212	1,9	20,96	4,2	7,2	9,0	7,2		
1,50	296	48,4	3,3	4,79	2,7	4,8			SK 0282.1 - 90 LP/4	25
	259	55,4	2,9	5,47	2,8	5,0				
	220	65	2,8	6,43	2,9	5,0				
	207	69	2,9	6,82	3,0	5,0				
	172	83,3	2,4	8,24	3,0	5,0				
	154	92,7	2,2	9,18	3,1	5,0				
	141	102	2,0	10,06	3,1	5,0				
	125	114	1,7	11,30	3,2	5,0				
	111	129	1,5	12,78	3,2	5,0				
1,50	99	145	1,4	14,36	3,3	5,0			SK 0282.1 - 90 LP/4	25
	88	163	1,2	16,12	3,4	5,0				
	78	185	1,1	18,24	3,4	5,0				
	75	192	1,0	18,96	3,4	5,0				
	66	218	0,9	21,53	3,4	5,0				
	54	266	0,8	26,32	3,4	5,0				

**2,20 kW**  
**3,00 kW**  
**4,00 kW**

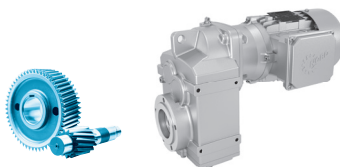

$P_1$ [kW]	$n_2$ [min <sup>-1</sup> ]	$M_2$ [Nm]	$f_B$	$i_{ges}$	$F_R$	$F_A$	$F_{R VL}$	$F_{A VL}$	Type	kg
<b>2,20</b>	51	409	1,0	28,54	3,4	6,3	7,8	7,2	<b>SK 1382.1 - 100 LP/4</b>	43
	44	473	0,8	32,99	-	6,0	7,2	7,2		
<b>2,20</b>	363	57,9	4,4	4,04	2,8	4,4	9,3	7,2	<b>SK 1282.1 - 100 LP/4</b>	42
	280	74,9	3,4	5,22	3,0	4,8	9,4	7,2		
	230	91,4	3,1	6,38	3,2	5,3	9,3	7,2		
	196	107	3,0	7,47	3,3	5,6	9,3	7,2		
	178	118	2,7	8,25	3,3	5,7	9,3	7,2		
	151	139	2,6	9,67	3,4	5,9	9,2	7,2		
	135	156	2,6	10,88	3,4	6,0	9,2	7,2		
	120	175	2,3	12,19	3,5	6,1	9,1	7,2		
	107	197	2,0	13,74	3,5	6,2	9,1	7,2		
	88	239	1,7	16,66	3,5	6,3	8,9	7,2		
	75	280	1,4	19,52	3,6	6,4	8,7	7,2		
<b>3,00</b>	362	79,2	3,2	4,04	2,7	4,1	9,1	7,2	<b>SK 1282.1 - 100 AP/4</b>	42
	279	103	2,5	5,22	2,8	4,4	9,3	7,2		
	229	125	2,3	6,38	2,9	4,8	9,3	7,2		
	195	147	2,2	7,47	3,0	5,1	9,2	7,2		
	177	162	2,0	8,25	3,0	5,2	9,2	7,2		
	151	190	1,9	9,67	3,1	5,4	9,1	7,2		
	134	213	1,9	10,88	3,0	5,4	9,0	7,2		
	120	239	1,7	12,19	3,0	5,4	8,9	7,2		
	106	270	1,5	13,74	3,0	5,4	8,8	7,2		
	88	327	1,2	16,66	2,9	5,3	8,4	7,2		
	75	383	1,0	19,52	2,8	5,3	8,0	7,2		
<b>4,00</b>	357	107	2,4	4,04	2,5	3,8	8,9	7,2	<b>SK 1282.1 - 112 MP/4</b>	50
	276	139	1,8	5,22	2,5	4,0	9,2	7,2		
	226	169	1,7	6,38	2,6	4,3	9,2	7,2		
	193	198	1,6	7,47	2,6	4,4	9,1	7,2		
	175	219	1,5	8,25	2,6	4,4	9,0	7,2		
	149	257	1,4	9,67	2,6	4,5	8,8	7,2		
	132	288	1,4	10,88	2,5	4,5	8,6	7,2		
	118	323	1,2	12,19	2,4	4,4	8,4	7,2		
	105	364	1,1	13,74	2,3	4,3	8,2	7,2		
	86	442	0,9	16,66	1,8	4,1	7,5	7,2		
	74	518	0,8	19,52	-	3,9	6,6	7,2		

---

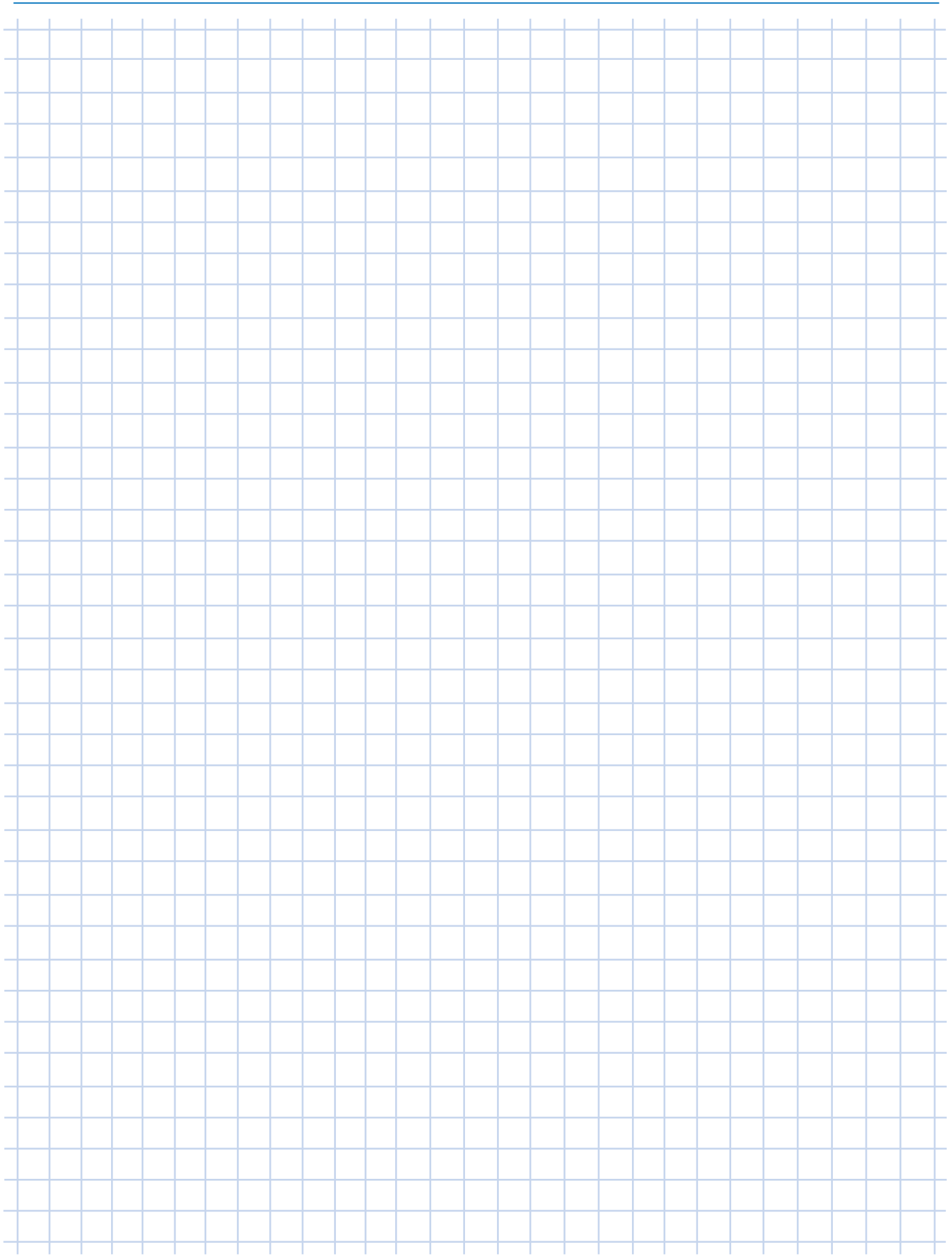



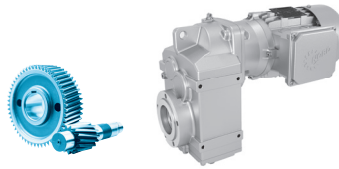

# SK 0182.1

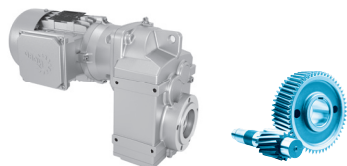

	$i_{ges}$	W			W			W			IEC						
		$n_2$	$M_{2max}$	$P_{1max}$	$n_2$	$M_{2max}$	$P_{1max}$	$n_2$	$M_{2max}$	$P_{1max}$	$f_B \Rightarrow 1-8$						
		$f_B = 1$	$f_B \geq 1$	$f_B \geq 1$	$f_B = 1$	$f_B \geq 1$	$f_B \geq 1$	$f_B = 1$	$f_B \geq 1$	$f_B \geq 1$	IEC						
		$n_1 = 1400 \text{ min}^{-1}$			$n_1 = 930 \text{ min}^{-1}$			$n_1 = 750 \text{ min}^{-1}$									
		[min <sup>-1</sup> ]	[Nm]	[kW]	[min <sup>-1</sup> ]	[Nm]	[kW]	[min <sup>-1</sup> ]	[Nm]	[kW]	63	71	80				
<b>SK 0182.1</b>	<b>153,54</b>	9,1	110	0,11	6,1	110	0,07	4,9	110	0,056	*	*	*				
	<b>147,93</b>	9,5	110	0,11	6,3	110	0,072	5,1	110	0,058	*	*	*				
<b>W + IEC</b>	<b>131,56</b>	11	110	0,12	7,1	110	0,081	5,7	110	0,066	*	*	*				
	<b>111,02</b>	13	110	0,15	8,4	110	0,1	6,8	110	0,078	*	*	*				
mm	<b>95,13</b>	15	110	0,17	9,8	110	0,11	7,9	110	0,09	*	*	*				
	<b>86,80</b>	16	110	0,19	11	110	0,12	8,6	110	0,1		*	*				
⇒ 26-27	<b>74,73</b>	19	110	0,22	12	110	0,14	10	110	0,12		*	*				
	<b>64,03</b>	22	110	0,25	15	110	0,17	12	110	0,13		*	*				
	<b>58,43</b>	24	130	0,33	16	130	0,22	13	130	0,17		*	*				
	<b>49,46</b>	28	130	0,39	19	130	0,26	15	130	0,21			*				
<b>W + NEMA</b>	<b>43,98</b>	32	130	0,43	21	130	0,29	17	130	0,23			*				
	<b>38,61</b>	36	130	0,49	24	130	0,33	19	130	0,26			*				
inch	<b>34,13</b>	41	130	0,56	27	130	0,37	22	130	0,3			*				
	<b>31,80</b>	44	130	0,6	29	130	0,4	24	130	0,32			*				
⇒ 54-55	<b>27,92</b>	50	130	0,68	33	130	0,45	27	130	0,37			*				
	<b>24,68</b>	57	130	0,75	38	130	0,5	30	130	0,4							
	<b>22,43</b>	62	120	0,75	41	120	0,5	33	120	0,4							
	<b>19,83</b>	71	120	0,75	47	120	0,5	38	120	0,4							
	<b>16,24</b>	86	130	0,75	57	130	0,5	46	130	0,4							
	<b>14,25</b>	98	130	0,75	65	130	0,5	53	130	0,4							
	<b>13,05</b>	107	130	0,75	71	130	0,5	57	130	0,4							
	<b>11,45</b>	122	130	0,75	81	130	0,5	65	130	0,4							
	<b>10,13</b>	138	130	0,75	92	130	0,5	74	130	0,4							
	<b>8,87</b>	158	130	0,75	105	130	0,5	85	130	0,4							
	<b>8,18</b>	171	130	0,75	114	130	0,5	92	130	0,4							
	<b>7,12</b>	196	130	0,75	131	130	0,5	105	130	0,4							
	<b>6,23</b>	225	130	0,75	149	130	0,5	120	130	0,4							
	<b>5,54</b>	253	120	0,75	168	120	0,5	135	120	0,4							
	<b>4,85</b>	289	120	0,75	192	120	0,5	155	120	0,4							

\* Achtung, überschreiten Sie nicht die maximale Antriebsleistung P1max gemäß der Spalte Typ W



	$i_{ges}$	W			W			W			IEC						
		$n_2$	$M_{2max}$	$P_{1max}$	$n_2$	$M_{2max}$	$P_{1max}$	$n_2$	$M_{2max}$	$P_{1max}$	$f_B \Rightarrow 1-8$						
		$f_B = 1$	$f_B \geq 1$	$f_B \geq 1$	$f_B = 1$	$f_B \geq 1$	$f_B \geq 1$	$f_B = 1$	$f_B \geq 1$	$f_B \geq 1$	IEC						
		$n_1 = 1400 \text{ min}^{-1}$			$n_1 = 930 \text{ min}^{-1}$			$n_1 = 750 \text{ min}^{-1}$									
		[min <sup>-1</sup> ]	[Nm]	[kW]	[min <sup>-1</sup> ]	[Nm]	[kW]	[min <sup>-1</sup> ]	[Nm]	[kW]	63	71	80	90			
<b>SK 0282.1</b>	<b>247,02</b>	<b>5,7</b>	180	0,11	3,8	180	0,071	3	180	0,057	*	*	*	*			
	<b>228,16</b>	<b>6,1</b>	200	0,13	4,1	200	0,085	3,3	200	0,069	*	*	*	*			
<b>W + IEC</b>	<b>201,65</b>	<b>6,9</b>	200	0,15	4,6	200	0,1	3,7	200	0,078	*	*	*	*			
	<b>190,64</b>	<b>7,3</b>	200	0,15	4,9	200	0,1	3,9	200	0,082	*	*	*	*			
 mm	<b>161,34</b>	<b>8,7</b>	200	0,18	5,8	200	0,12	4,6	200	0,1	*	*	*	*			
	<b>140,98</b>	<b>9,9</b>	200	0,21	6,6	200	0,14	5,3	200	0,11		*	*	*			
$\Rightarrow$  26-27	<b>126,98</b>	<b>11</b>	200	0,23	7,3	200	0,15	5,9	200	0,12		*	*	*			
	<b>110,96</b>	<b>13</b>	200	0,26	8,4	200	0,18	6,8	200	0,14		*	*	*			
	<b>103,89</b>	<b>13</b>	200	0,28	9	200	0,19	7,2	200	0,15		*	*	*			
	<b>92,51</b>	<b>15</b>	200	0,32	10	200	0,21	8,1	200	0,17		*	*	*			
<b>W + NEMA</b>	<b>75,69</b>	<b>18</b>	200	0,39	12	200	0,26	9,9	200	0,21			*	*			
	<b>66,66</b>	<b>21</b>	200	0,44	14	200	0,29	11	200	0,24			*	*			
 inch	<b>53,03</b>	<b>26</b>	180	0,5	18	180	0,33	14	180	0,27			*	*			
	<b>43,78</b>	<b>32</b>	200	0,67	21	200	0,44	17	200	0,36			*	*			
$\Rightarrow$  54-55	<b>38,14</b>	<b>37</b>	200	0,77	24	200	0,51	20	200	0,41				*			
	<b>33,44</b>	<b>42</b>	200	0,88	28	200	0,58	22	200	0,47				*			
	<b>29,56</b>	<b>47</b>	200	0,99	31	200	0,66	25	200	0,53				*			
	<b>26,32</b>	<b>53</b>	200	1,11	35	200	0,74	28	200	0,6				*			
	<b>21,53</b>	<b>65</b>	200	1,36	43	200	0,9	35	200	0,73				*			
	<b>18,96</b>	<b>74</b>	200	1,5	49	200	1	40	200	0,8							
	<b>18,24</b>	<b>77</b>	200	1,5	51	200	1	41	200	0,8							
	<b>16,12</b>	<b>87</b>	200	1,5	58	200	1	47	200	0,8							
	<b>14,36</b>	<b>98</b>	200	1,5	65	200	1	52	200	0,8							
	<b>12,78</b>	<b>110</b>	200	1,5	73	200	1	59	200	0,8							
	<b>11,30</b>	<b>124</b>	200	1,5	82	200	1	66	200	0,8							
	<b>10,06</b>	<b>139</b>	200	1,5	92	200	1	75	200	0,8							
	<b>9,18</b>	<b>153</b>	200	1,5	102	200	1	82	200	0,8							
	<b>8,24</b>	<b>170</b>	200	1,5	113	200	1	91	200	0,8							
	<b>6,82</b>	<b>205</b>	200	1,5	136	200	1	110	200	0,8							
	<b>6,43</b>	<b>218</b>	180	1,5	145	180	1	117	180	0,8							
	<b>5,47</b>	<b>256</b>	160	1,5	170	160	1	137	160	0,8							
	<b>4,79</b>	<b>293</b>	160	1,5	195	160	1	157	160	0,8							

\* Achtung, überschreiten Sie nicht die maximale Antriebsleistung P1max gemäß der Spalte Typ W

# SK 1282.1

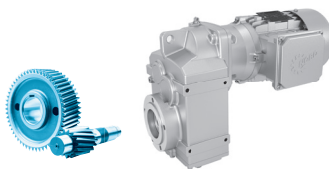



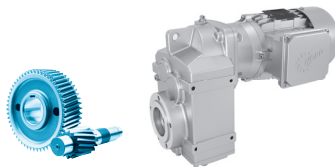

	$i_{ges}$	W			W			W			IEC					
		$n_2$	$M_{2max}$	$P_{1max}$	$n_2$	$M_{2max}$	$P_{1max}$	$n_2$	$M_{2max}$	$P_{1max}$	$f_B \Rightarrow$ 1-8					
		$f_B = 1$	$f_B \geq 1$	$f_B \geq 1$	$f_B = 1$	$f_B \geq 1$	$f_B \geq 1$	$f_B = 1$	$f_B \geq 1$	$f_B \geq 1$	IEC					
		$n_1 = 1400 \text{ min}^{-1}$			$n_1 = 930 \text{ min}^{-1}$			$n_1 = 750 \text{ min}^{-1}$								
		[min <sup>-1</sup> ]	[Nm]	[kW]	[min <sup>-1</sup> ]	[Nm]	[kW]	[min <sup>-1</sup> ]	[Nm]	[kW]	63	71	80	90	100	112
<b>SK 1282.1</b>	<b>24,57</b>	57	400	2,05	38	400	1,36	31	400	1,1						
	<b>20,96</b>	67	400	2,05	44	400	1,36	36	400	1,1						
<b>W + IEC</b>	<b>19,52</b>	72	400	3,0	48	400	2,00	38	400	1,61						*
	<b>16,66</b>	84	400	3,3	56	400	2,19	45	400	1,77						*
 mm	<b>13,74</b>	102	400	3,45	68	400	2,29	55	400	1,85						*
	<b>12,19</b>	115	400	4,0	76	400	2,66	62	400	2,14						
26-27	<b>10,88</b>	129	400	4,0	86	400	2,66	69	400	2,14						
	<b>9,67</b>	145	360	4,0	96	360	2,66	78	360	2,14						
	<b>8,25</b>	170	320	4,0	113	320	2,66	91	320	2,14						
	<b>7,47</b>	187	320	4,0	124	320	2,66	100	320	2,14						
<b>W + NEMA</b>	<b>6,38</b>	220	285	4,0	146	285	2,66	118	285	2,14						
	<b>5,22</b>	268	255	4,0	178	255	2,66	144	255	2,14						
 inch	<b>4,04</b>	347	255	4,0	230	255	2,66	186	255	2,14						
54-55																

\* Achtung, überschreiten Sie nicht die maximale Antriebsleistung P1max gemäß der Spalte Typ W





	$i_{ges}$	W			W			W			IEC						
		$n_2$	$M_{2max}$	$P_{1max}$	$n_2$	$M_{2max}$	$P_{1max}$	$n_2$	$M_{2max}$	$P_{1max}$	$f_B \Rightarrow 1-8$						
		$f_B = 1 \quad f_B \geq 1$			$f_B = 1 \quad f_B \geq 1$			$f_B = 1 \quad f_B \geq 1$			IEC						
		$n_1 = 1400 \text{ min}^{-1}$			$n_1 = 930 \text{ min}^{-1}$			$n_1 = 750 \text{ min}^{-1}$			63	71	80	90	100		
		[min <sup>-1</sup> ]	[Nm]	[kW]	[min <sup>-1</sup> ]	[Nm]	[kW]	[min <sup>-1</sup> ]	[Nm]	[kW]							
<b>SK 1382.1</b>	<b>356,89</b>	<b>3,9</b>	360	0,15	2,6	360	0,10	2,1	360	0,079	*	*	*	*			
	<b>304,47</b>	<b>4,6</b>	360	0,17	3,1	360	0,12	2,5	360	0,09	*	*	*	*			
<b>W + IEC</b>	<b>287,37</b>	<b>4,9</b>	400	0,2	3,2	400	0,14	2,6	400	0,11		*	*	*			
	<b>245,16</b>	<b>5,7</b>	400	0,24	3,8	400	0,16	3,1	400	0,13		*	*	*			
 mm	<b>217,62</b>	<b>6,4</b>	400	0,27	4,3	400	0,18	3,4	400	0,14		*	*	*			
	<b>179,22</b>	<b>7,8</b>	400	0,33	5,2	400	0,22	4,2	400	0,18		*	*	*			
$\Rightarrow$  26-27	<b>159,09</b>	<b>8,8</b>	400	0,37	5,8	400	0,24	4,7	400	0,2			*	*			
	<b>135,72</b>	<b>10</b>	400	0,43	6,9	400	0,29	5,5	400	0,23			*	*			
	<b>121,52</b>	<b>12</b>	400	0,48	7,7	400	0,32	6,2	400	0,26			*	*			
	<b>103,68</b>	<b>14</b>	400	0,57	9	400	0,38	7,2	400	0,3			*	*			
<b>W + NEMA</b>	<b>97,22</b>	<b>14</b>	400	0,6	9,6	400	0,40	7,7	400	0,32			*	*			
	<b>82,94</b>	<b>17</b>	400	0,71	11	400	0,47	9	400	0,38			*	*			
 inch	<b>68,50</b>	<b>20</b>	400	0,86	14	400	0,57	11	400	0,46							
	<b>60,26</b>	<b>23</b>	400	0,97	15	400	0,65	12	400	0,52							
$\Rightarrow$  54-55	<b>54,32</b>	<b>26</b>	400	1,08	17	400	0,72	14	400	0,58				*	*		
	<b>51,41</b>	<b>27</b>	400	1,14	18	400	0,76	15	400	0,61				*	*		
	<b>44,19</b>	<b>32</b>	400	1,33	21	400	0,88	17	400	0,71				*	*		
	<b>38,67</b>	<b>36</b>	400	1,52	24	400	1,01	19	400	0,81				*	*		
	<b>32,99</b>	<b>42</b>	400	1,78	28	400	1,18	23	400	0,95				*	*		
	<b>28,54</b>	<b>49</b>	400	2,05	33	400	1,36	26	400	1,1				*	*		

\* Achtung, überschreiten Sie nicht die maximale Antriebsleistung P1max gemäß der Spalte Typ W

# SK 0182.1

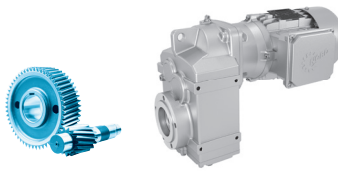

## SK 0182.1 AXZ

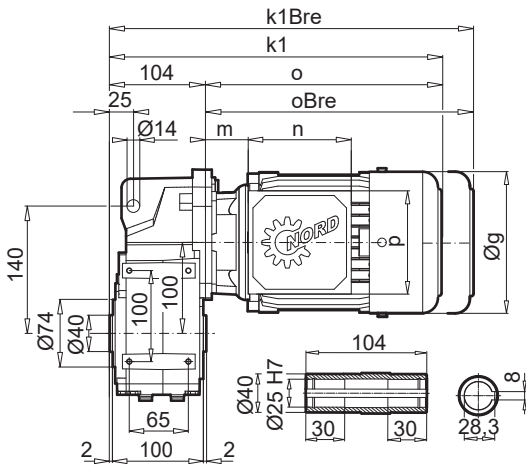

## SK 0182.1 VXZ

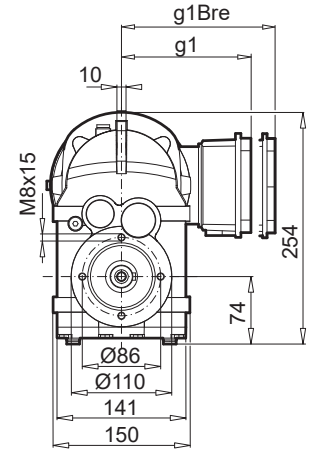
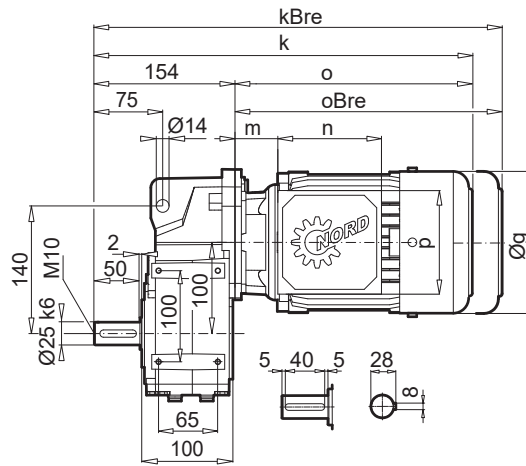

## SK 0182.1 AXF

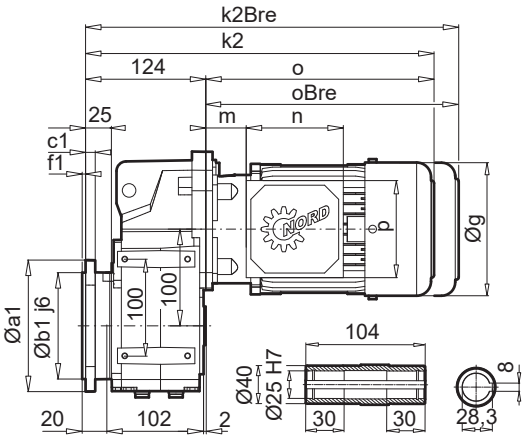

## SK 0182.1 VXF

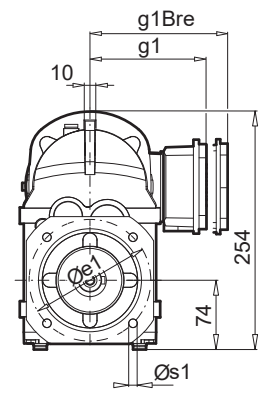
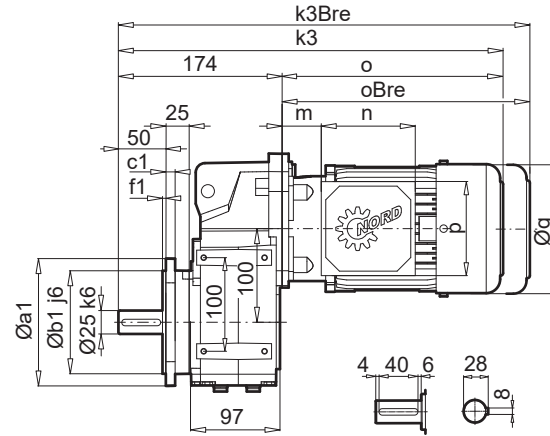

a1	b1	c1	e1	f1	s1
160	110	10	130	3,5	4 x 9,0

## SK 0182.1 AXFB / AXZB

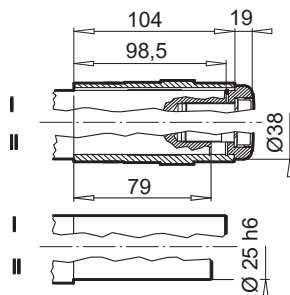

## SK 0182.1 AXZG / VXZG

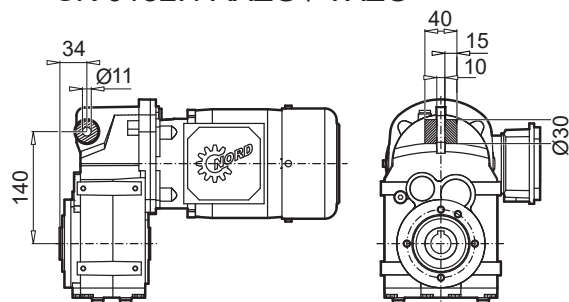

	63 SP/LP	71 SP/LP	80 SP/LP		
<b>g</b>	130	145	164		
<b>g1 / g1Bre</b>	116 / 123	124 / 133	142 / 142		
<b>k / kBre</b>	350 / 406	390 / 448	415 / 479		
<b>k1 / k1Bre</b>	300 / 356	340 / 398	365 / 429		
<b>k2 / k2Bre</b>	321 / 377	361 / 419	386 / 450		
<b>k3 / k2Bre</b>	371 / 427	411 / 469	436 / 500		
<b>o / oBre</b>	196 / 252	236 / 294	261 / 325		
<b>m / mBre</b>	16 / 22	42 / 48	47 / 50		
<b>n / nBre</b>	100 / 134	100 / 134	114 / 153		
<b>p / pBre</b>	100 / 89	100 / 89	114 / 108		

W ⇒ 26

IEC ⇒ 27

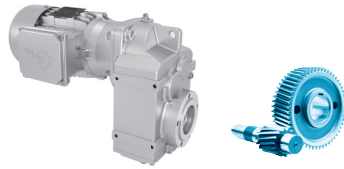

## SK 0282.1 AXZ

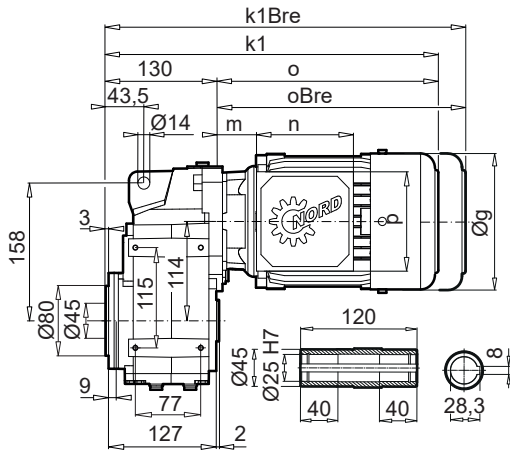

## SK 0282.1 VXZ

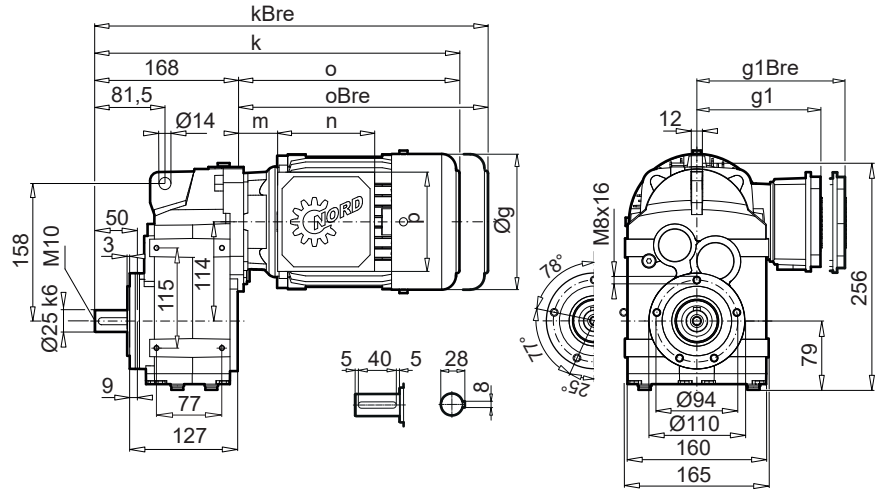

## SK 0282.1 AXF

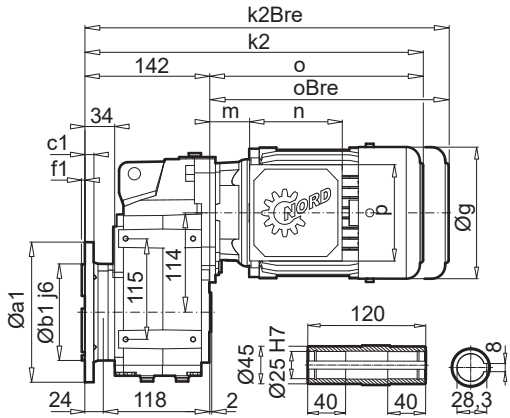

## SK 0282.1 VXF

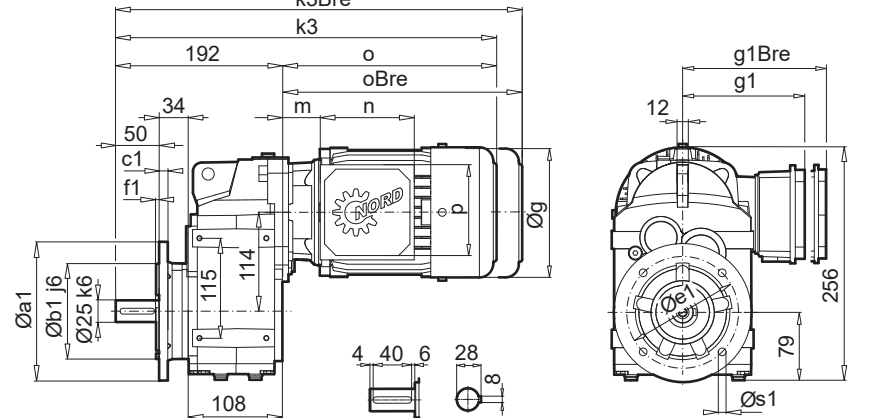

a1	b1	c1	e1	f1	s1
160	110	10	130	3,5	4 x 9,0

## SK 0282.1 AXFB / AXZB

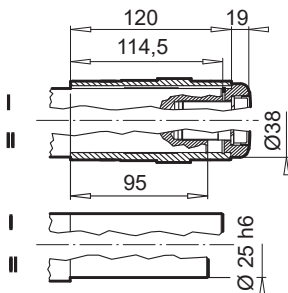

## SK 0282.1 AXZG / VXZG

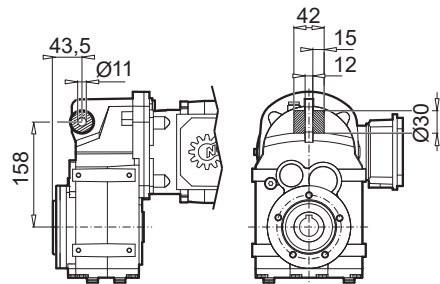

## SK 0282.1 AXZSH

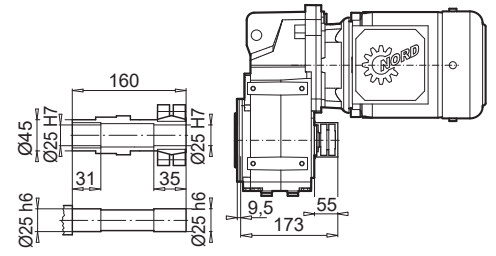

	63 SP/LP	71 SP/LP	80 SP/LP	90 SP/LP	
<b>g</b>	130	145	164	164	
<b>g1 / g1Bre</b>	116 / 123	124 / 133	142 / 142	147 / 147	
<b>k / kBre</b>	364 / 420	404 / 462	429 / 479	470 / 545	
<b>k1 / k1Bre</b>	326 / 382	366 / 424	391 / 455	432 / 507	
<b>k2 / k2Bre</b>	339 / 395	379 / 437	403 / 450	445 / 520	
<b>k3 / k3Bre</b>	388 / 444	428 / 486	436 / 500	494 / 569	
<b>o / oBre</b>	196 / 252	236 / 294	261 / 325	302 / 377	
<b>m / mBre</b>	16 / 22	42 / 48	47 / 50	52 / 55	
<b>n / nBre</b>	100 / 134	100 / 134	114 / 153	114 / 153	
<b>p / pBre</b>	100 / 89	100 / 89	114 / 108	114 / 108	
					W ⇒ 26
					IEC ⇒ 27

# SK 0182.1 ... N

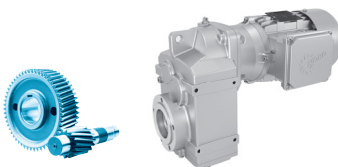

## SK 0182.1 AXZN

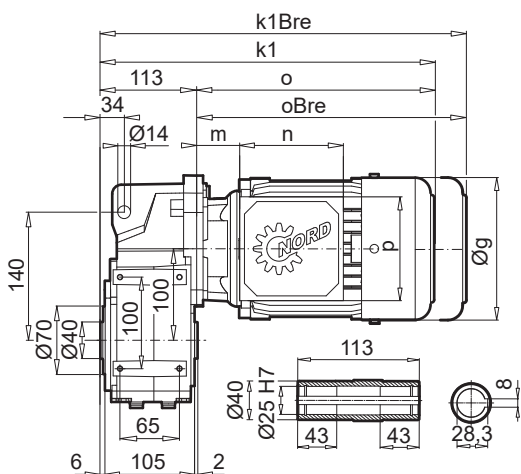

## SK 0182.1 VXZN

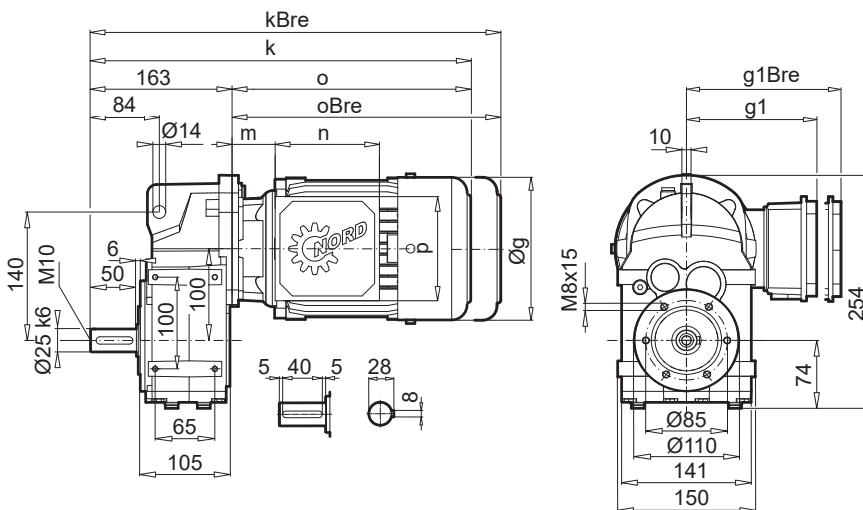

## SK 0182.1 AXZ(N)B

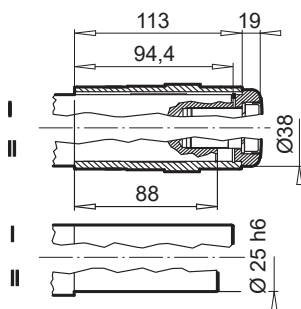

## SK 0182.1 AXZ(N)G / VXZ(N)G

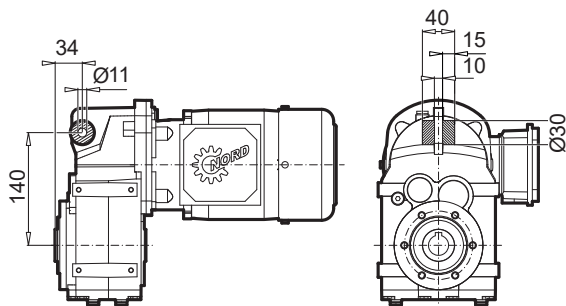

	63 SP/LP	71 SP/LP	80 SP/LP		
<b>g</b>	130	145	164		
<b>g1 / g1Bre</b>	116 / 123	124 / 133	142 / 142		W ⇒ 26
<b>k / kBre</b>	359 / 415	399 / 457	424 / 488		
<b>k1 / k1Bre</b>	309 / 365	349 / 407	374 / 438		
<b>o / oBre</b>	196 / 252	236 / 294	261 / 325		
<b>m / mBre</b>	16 / 22	42 / 48	47 / 50		
<b>n / nBre</b>	100 / 134	100 / 134	114 / 153		
<b>p / pBre</b>	100 / 89	100 / 89	114 / 108		IEC ⇒ 27

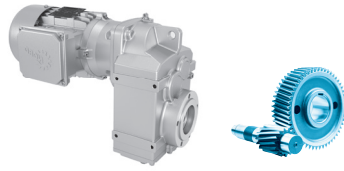

**SK 0282.1 AXZN**

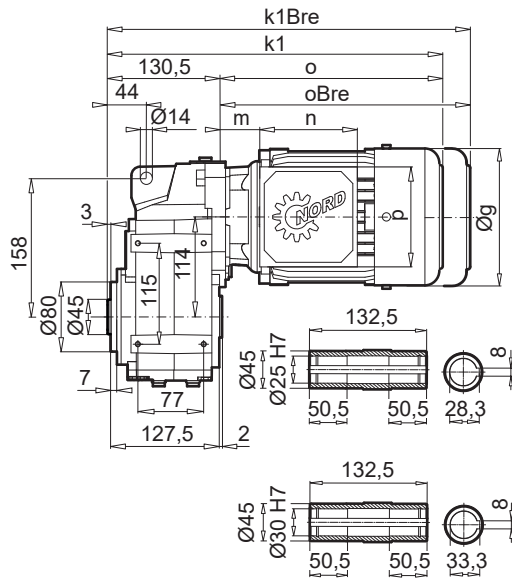

**SK 0282.1 VXZN**

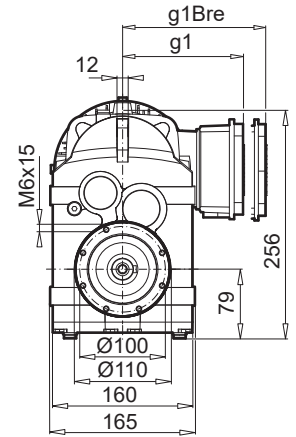
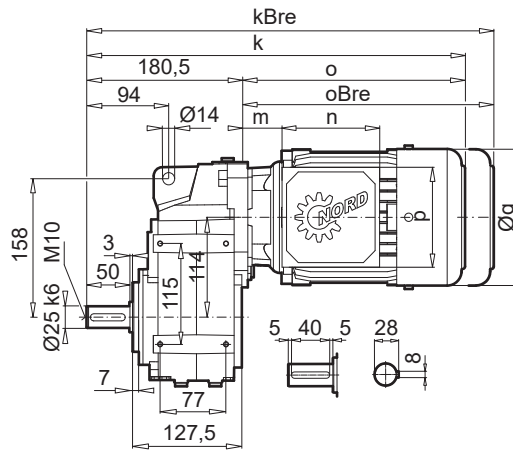

**SK 0282.1 AXZ(N)B**

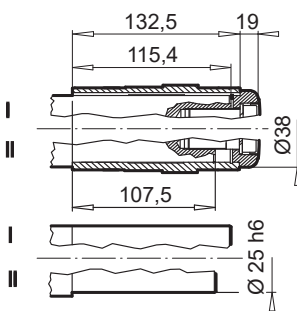

**SK 0282.1 AXZ(N)G / VXZ(N)G**

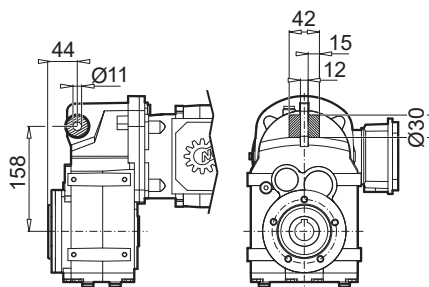

**SK 0282.1 AXZ SH**

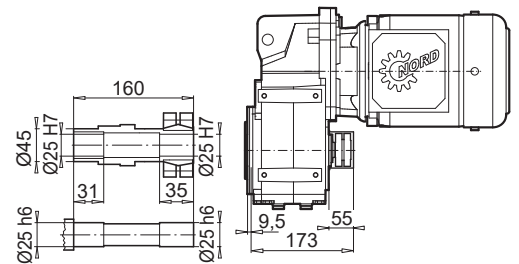

	63 SP/LP	71 SP/LP	80 SP/LP	90 SP/LP	
<b>g</b>	130	145	164	164	
<b>g1 / g1Bre</b>	116 / 123	124 / 133	142 / 142	147 / 147	W ⇒ 26
<b>k / kBre</b>	376,5 / 432,5	416,5 / 474,5	441,5 / 491,5	482,5 / 547,5	
<b>k1 / k1Bre</b>	326,5 / 382,5	366,5 / 424,5	391,5 / 455,5	432,5 / 507,5	
<b>o / oBre</b>	196 / 252	236 / 294	261 / 325	302 / 377	
<b>m / mBre</b>	16 / 22	42 / 48	47 / 50	52 / 55	IEC ⇒ 27
<b>n / nBre</b>	100 / 134	100 / 134	114 / 153	114 / 153	
<b>p / pBre</b>	100 / 89	100 / 89	114 / 108	114 / 108	

# SK 1282.1

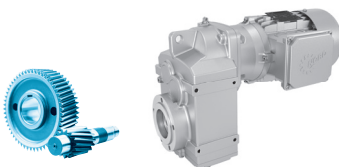

## SK 1282.1 AXZ

## SK 1282.1 VXZ

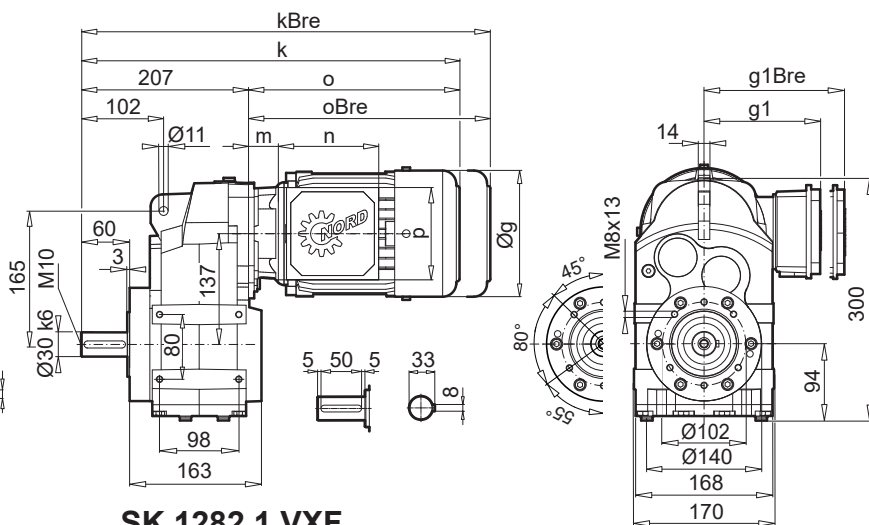
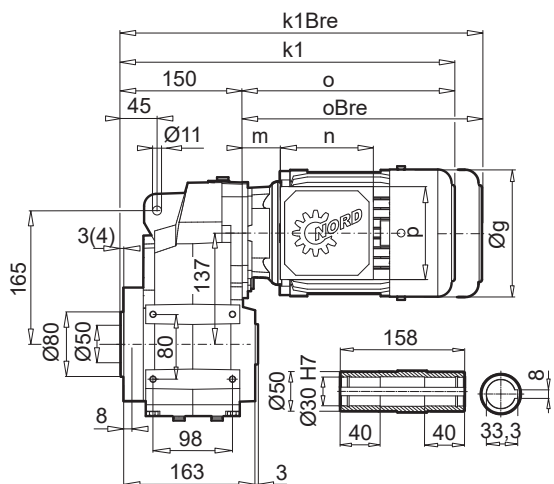

## SK 1282.1 AXF

## SK 1282.1 VXF

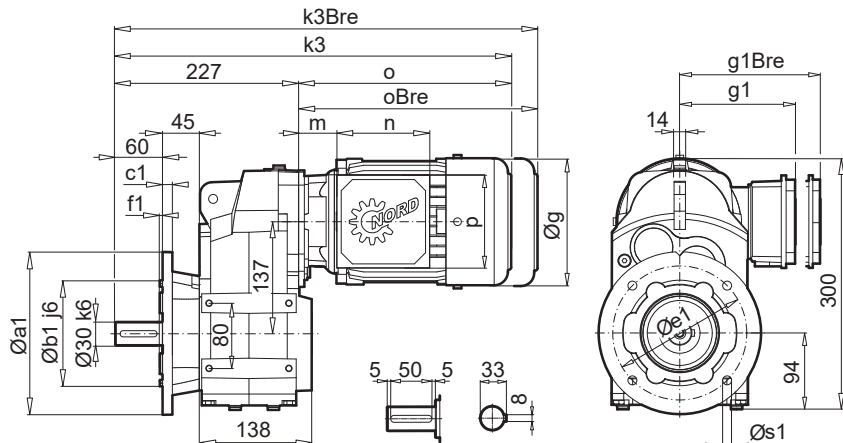
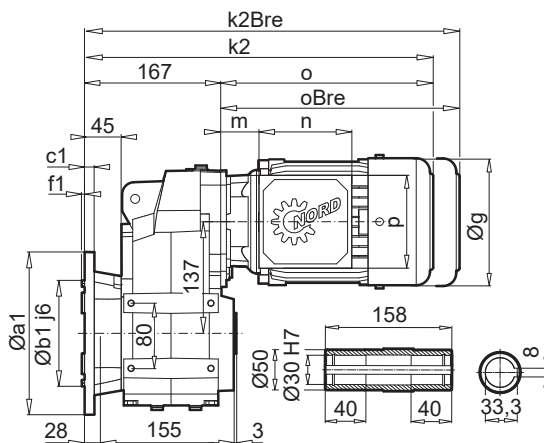

a1	b1	c1	e1	f1	s1
200	130	12	165	3,5	4 x 11,0

## SK 1282.1 EA

## SK 1282.1 AXFB/AXZB

## SK 1282.1 AXZG/VXZG

## SK 1282.1 AXZSH

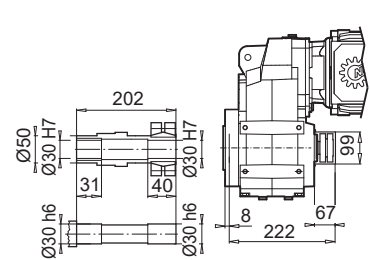
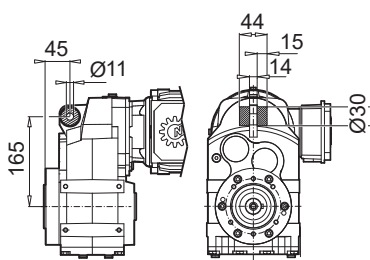
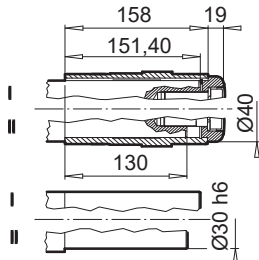
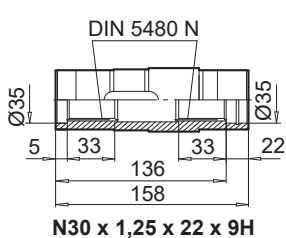

	63 SP/LP	71 SP/LP	80 SP/LP	90 SP/LP	100 LP/AP	112 MP	
<b>g</b>	130	145	164	184	202	226	
<b>g1 / g1Bre</b>	116 / 123	124 / 133	142 / 142	147 / 147	169 / 172	179 / 182	
<b>k / kBre</b>	403 / 459	443 / 501	468 / 532	509 / 584	539 / 630	562 / 656	W ⇨
<b>k1 / k1Bre</b>	346 / 402	386 / 444	411 / 475	452 / 527	482 / 573	505 / 599	
<b>k2 / k2Bre</b>	364 / 420	403 / 462	428 / 493	470 / 545	500 / 590	522 / 616	
<b>k3 / k3Bre</b>	423 / 479	463 / 521	488 / 552	530 / 604	560 / 650	582 / 676	
<b>o / oBre</b>	196 / 252	236 / 294	261 / 325	302 / 377	332 / 423	355 / 449	IEC ⇨
<b>m / mBre</b>	16 / 22	42 / 48	47 / 50	52 / 55	58 / 62	64 / 67	
<b>n / nBre</b>	100 / 134	100 / 134	114 / 153	114 / 153	114 / 153	114 / 153	
<b>p / pBre</b>	100 / 89	100 / 89	114 / 108	114 / 108	114 / 108	114 / 108	



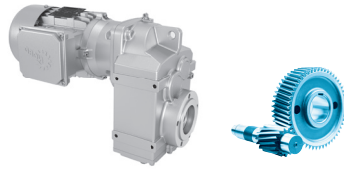

## SK 1282.1 AXF VL2/VL3

## SK 1282.1 VXF VL2/VL3

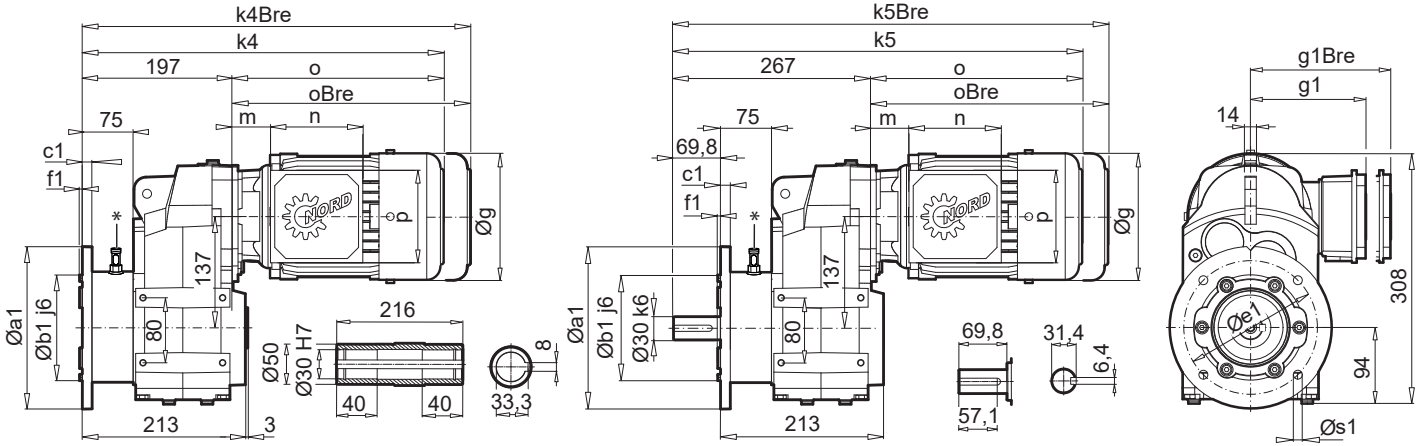

\* Ölleckanzeige oder Ölsensor für Option VL3

a1	b1	c1	e1	f1	s1
200	130	12	165	3,5	4 x 11,0

## SK 1282.1 AXF VL2/3 B

## SK 1282.1 AXF VL2/3 SH

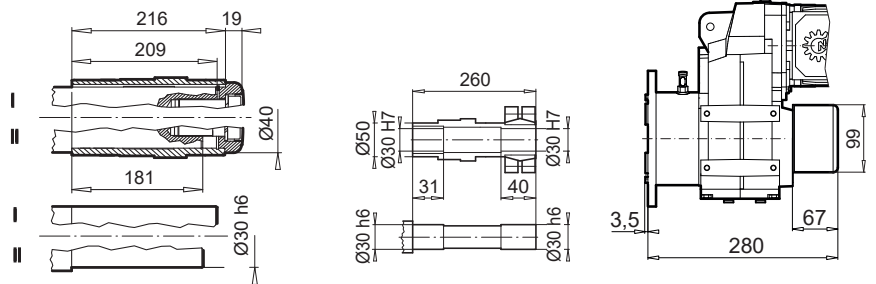

	63 SP/LP	71 SP/LP	80 SP/LP	90 SP/LP	100 LP/AP	112 MP	
<b>g</b>	130	145	164	184	202	226	
<b>g1 / g1Bre</b>	116 / 123	124 / 133	142 / 142	147 / 147	169 / 172	179 / 182	W ⇒
<b>k4 / k4Bre</b>	393 / 449	433 / 491	458 / 522	499 / 574	529 / 620	552 / 646	
<b>k5 / k5Bre</b>	463 / 519	503 / 561	528 / 592	570 / 644	600 / 690	622 / 716	
<b>o / oBre</b>	196 / 252	236 / 294	261 / 325	302 / 377	332 / 423	355 / 449	
<b>m / mBre</b>	16 / 22	42 / 48	47 / 50	52 / 55	58 / 62	64 / 67	IEC ⇒
<b>n / nBre</b>	100 / 134	100 / 134	114 / 153	114 / 153	114 / 153	114 / 153	
<b>p / pBre</b>	100 / 89	100 / 89	114 / 108	114 / 108	114 / 108	114 / 108	

# SK 1282.1 ... N

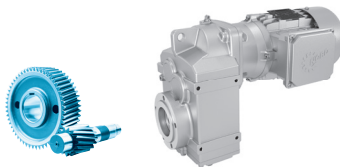

## SK 1282.1 AXZN

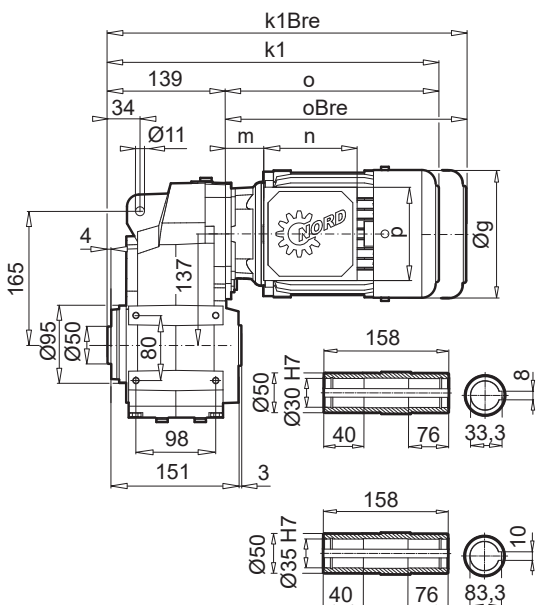

## SK 1282.1 VXZN

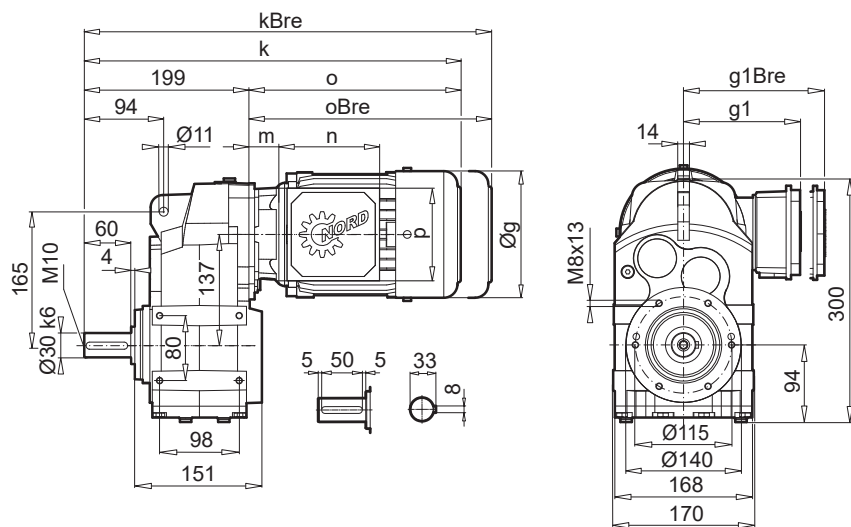

## SK 1282.1 EA

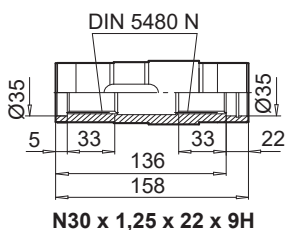

## SK 1282.1 AXZ(N)B

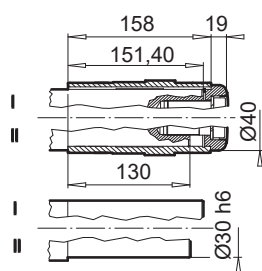

## SK 1282.1 AXZ(N)G / VXZ(N)G

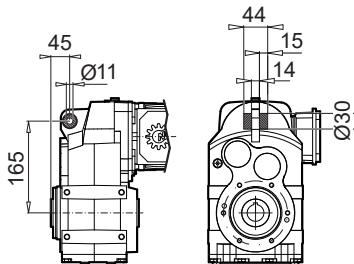

## SK 1282.1 AXZ(N)SH

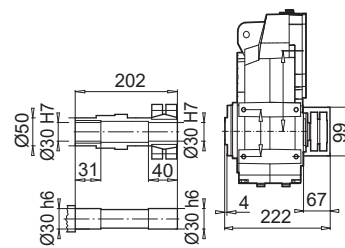

	63 SP/LP	71 SP/LP	80 SP/LP	90 SP/LP	100 LP/AP	112 MP	
<b>g</b>	130	145	164	184	202	226	
<b>g1 / g1Bre</b>	116 / 123	124 / 133	142 / 142	147 / 147	169 / 172	179 / 182	
<b>k / kBre</b>	395 / 451	435 / 493	460 / 524	501 / 576	531 / 622	554 / 648	W ⇨ 26
<b>k1 / k1Bre</b>	335 / 391	375 / 433	400 / 464	441 / 516	471 / 562	494 / 588	
<b>k2 / k2Bre</b>	364 / 420	403 / 462	428 / 493	470 / 545	500 / 590	522 / 616	
<b>k3 / k3Bre</b>	423 / 479	463 / 521	488 / 552	530 / 604	560 / 650	582 / 676	
<b>o / oBre</b>	196 / 252	236 / 294	261 / 325	302 / 377	332 / 423	355 / 449	IEC ⇨ 27
<b>m / mBre</b>	16 / 22	42 / 48	47 / 50	52 / 55	58 / 62	64 / 67	
<b>n / nBre</b>	100 / 134	100 / 134	114 / 153	114 / 153	114 / 153	114 / 153	
<b>p / pBre</b>	100 / 89	100 / 89	114 / 108	114 / 108	114 / 108	114 / 108	

---

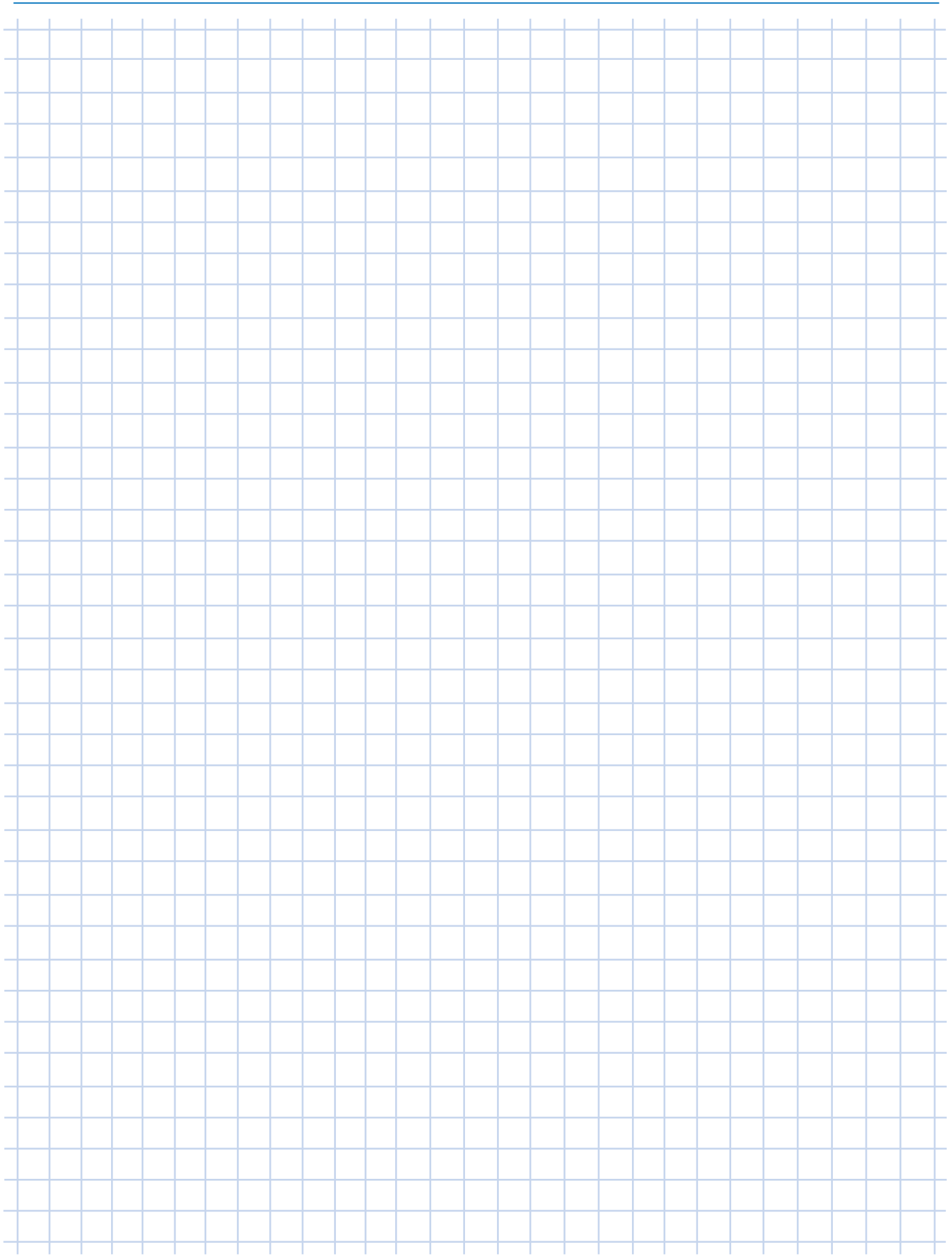

# SK 1382.1

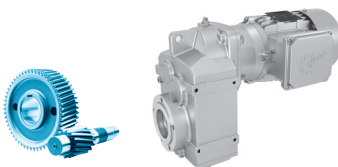

## SK 1382.1 AXZ

## SK 1382.1 VXZ

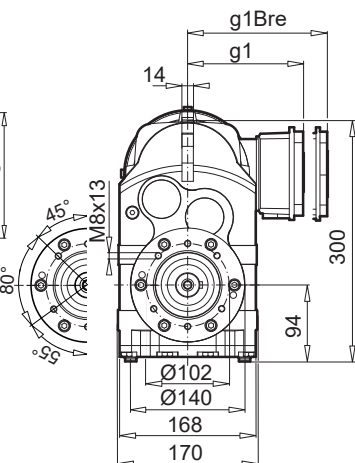
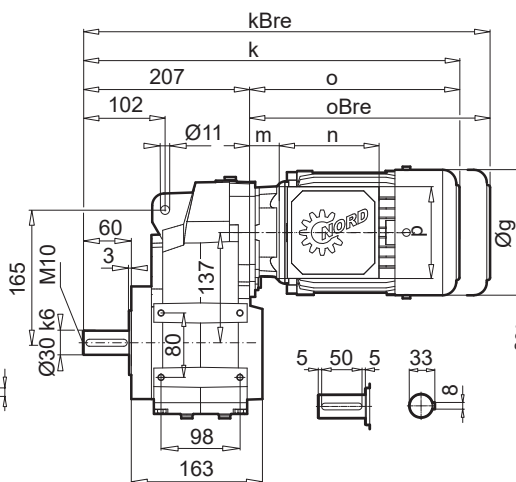
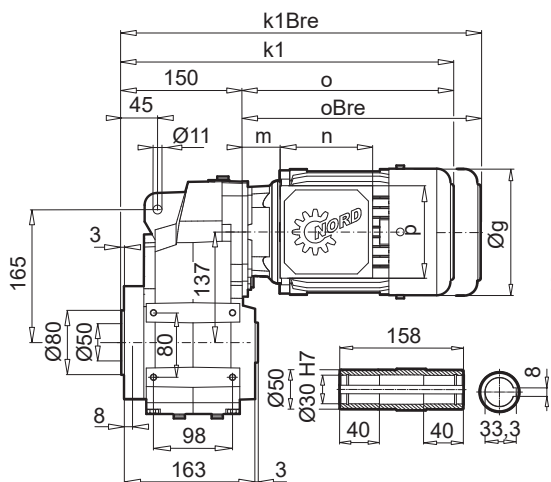

## SK 1382.1 AXF

## SK 1382.1 VXF

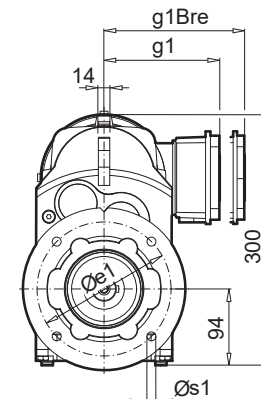
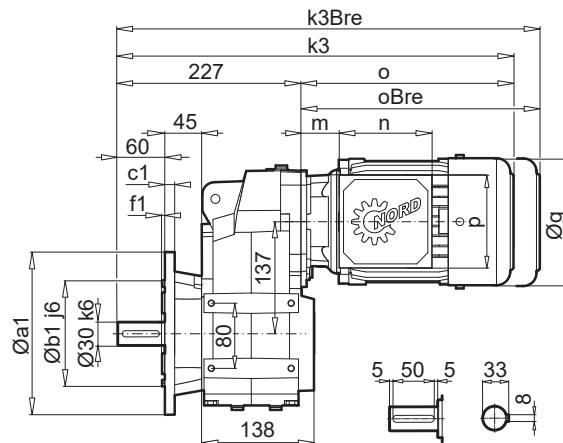
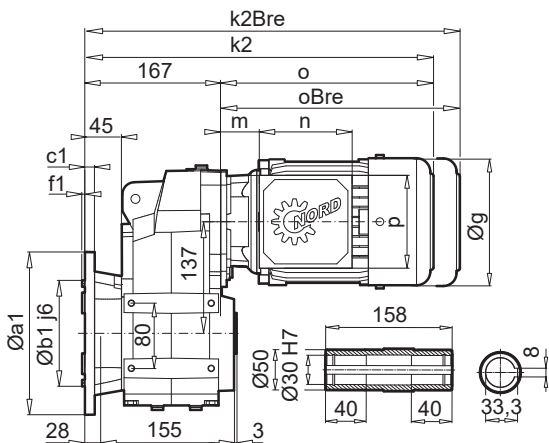

a1	b1	c1	e1	f1	s1
200	130	12	165	3,5	4 x 11,0

## SK 1382.1 EA

## SK 1382.1 AXFB/AXZB

## SK 1382.1 AXZG/VXZG

## SK 1382.1 AXZSH

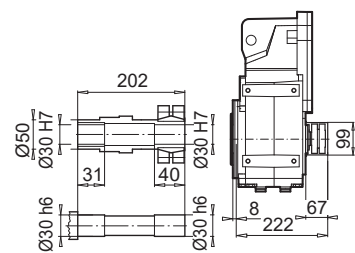
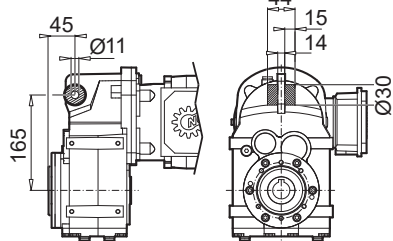
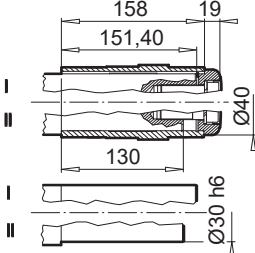
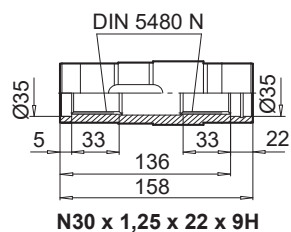

	63 SP/LP	71 SP/LP	80 SP/LP	90 SP/LP	100 LP/AP	
<b>g</b>	130	145	164	184	202	
<b>g1 / g1Bre</b>	116 / 123	124 / 133	142 / 142	147 / 147	169 / 172	
<b>k / kBre</b>	403 / 459	443 / 501	468 / 532	509 / 584	539 / 630	
<b>k1 / k1Bre</b>	346 / 402	386 / 444	411 / 475	452 / 527	482 / 573	W ⇒
<b>k2 / k2Bre</b>	364 / 420	403 / 462	428 / 493	470 / 545	500 / 590	
<b>k3 / k3Bre</b>	423 / 479	463 / 521	488 / 552	530 / 604	560 / 650	
<b>o / oBre</b>	196 / 252	236 / 294	261 / 325	302 / 377	332 / 423	IEC ⇒
<b>m / mBre</b>	16 / 22	42 / 48	47 / 50	52 / 55	58 / 62	
<b>n / nBre</b>	100 / 134	100 / 134	114 / 153	114 / 153	114 / 153	
<b>p / pBre</b>	100 / 89	100 / 89	114 / 108	114 / 108	114 / 108	

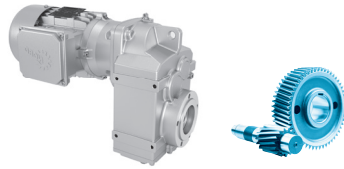

## SK 1382.1 AXF VL2/VL3

## SK 1382.1 VXF VL2/VL3

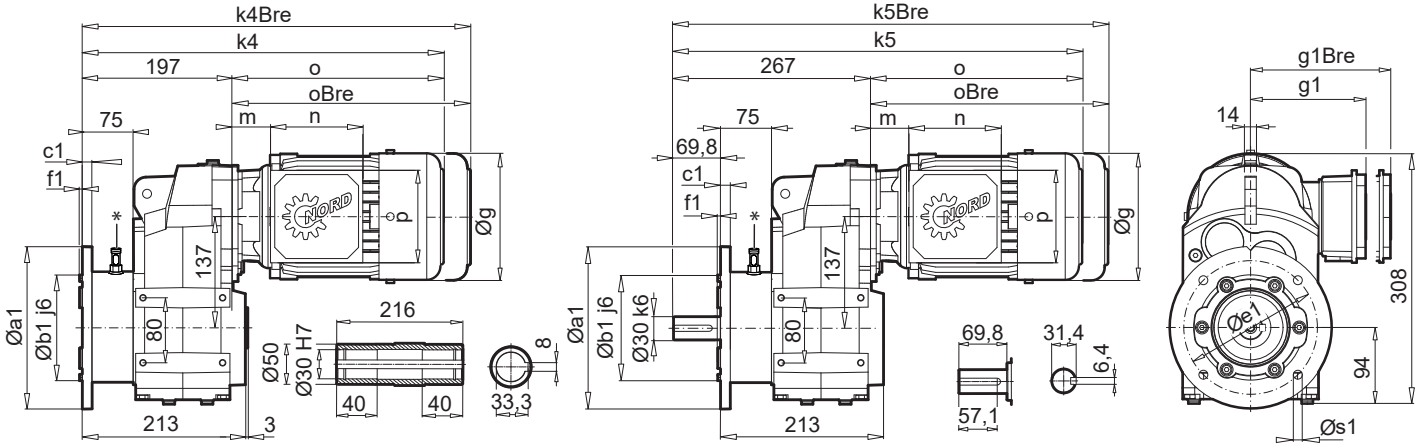

\* Ölleckanzeige oder Ölsensor für Option VL3

a1	b1	c1	e1	f1	s1
200	130	12	165	3,5	4 x 11,0

## SK 1382.1 AXF VL2/3 B

## SK 1382.1 AXF VL2/3 SH

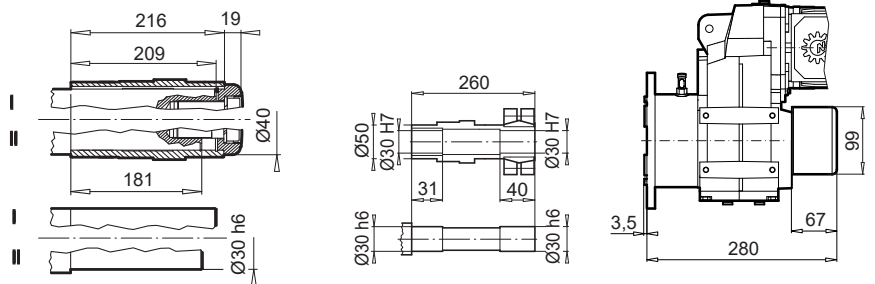

	63 SP/LP	71 SP/LP	80 SP/LP	90 SP/LP	100 LP/AP	112 MP	
<b>g</b>	130	145	164	184	202	226	
<b>g1 / g1Bre</b>	116 / 123	124 / 133	142 / 142	147 / 147	169 / 172	179 / 182	W ⇒
<b>k4 / k4Bre</b>	393 / 449	433 / 491	458 / 522	499 / 574	529 / 620	552 / 646	
<b>k5 / k5Bre</b>	463 / 519	503 / 561	528 / 592	570 / 644	600 / 690	622 / 716	
<b>o / oBre</b>	196 / 252	236 / 294	261 / 325	302 / 377	332 / 423	355 / 449	IEC ⇒
<b>m / mBre</b>	16 / 22	42 / 48	47 / 50	52 / 55	58 / 62	64 / 67	
<b>n / nBre</b>	100 / 134	100 / 134	114 / 153	114 / 153	114 / 153	114 / 153	
<b>p / pBre</b>	100 / 89	100 / 89	114 / 108	114 / 108	114 / 108	114 / 108	

# SK 1382.1 ... N

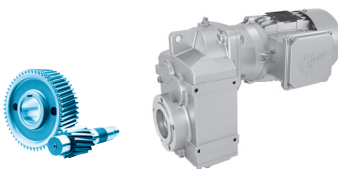

## SK 1382.1 AXZN

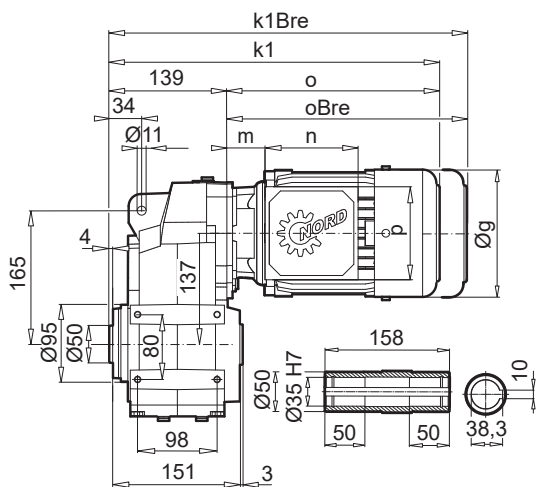

## SK 1382.1 VXZN

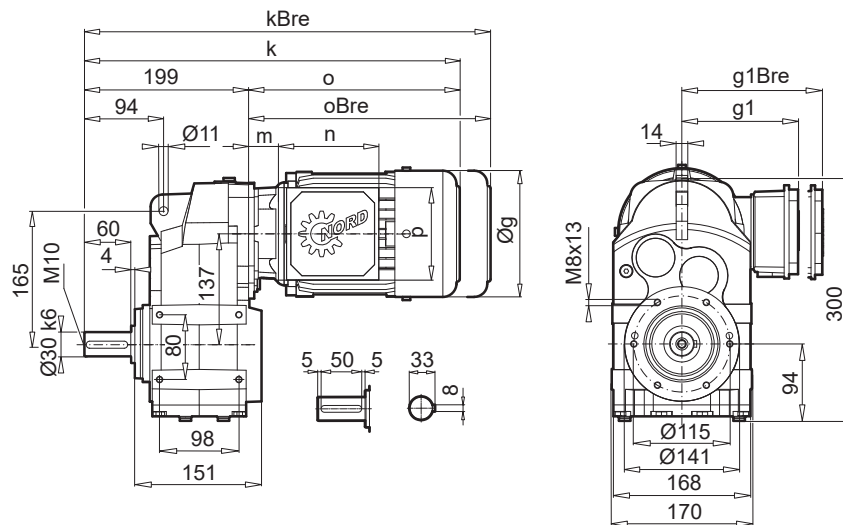

## SK 1382.1 EA

## SK 1382.1 AXFB/AXZ(N)B

## SK 1382.1 AXZ(N)G/VXZ(N)G

## SK 1382.1 AXZ(N)SH

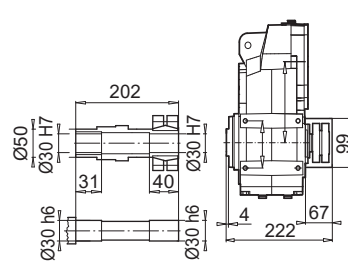
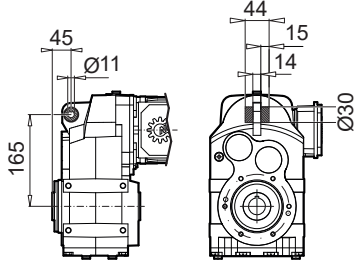
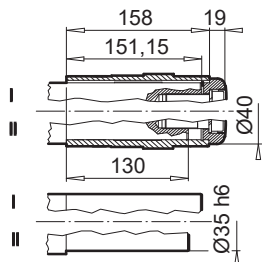
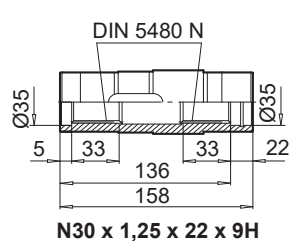

	63 SP/LP	71 SP/LP	80 SP/LP	90 SP/LP	100 LP/AP	
<b>g</b>	130	145	164	184	202	
<b>g1 / g1Bre</b>	116 / 123	124 / 133	142 / 142	147 / 147	169 / 172	
<b>k / kBre</b>	403 (395) / 459 (451)	443 (435) / 501 (493)	468 (460) / 532 (524)	509 (501) / 584 (576)	539 (531) / 630 (622)	
<b>k1 / k1Bre</b>	346 (335) / 402 (391)	386 (375) / 444 (433)	411 (400) / 475 (464)	452 (441) / 527 (516)	482 (471) / 573 (562)	W ⇒
<b>k2 / k2Bre</b>	364 / 420	403 / 462	428 / 493	470 / 545	500 / 590	
<b>k3 / k3Bre</b>	423 / 479	463 / 521	488 / 552	530 / 604	560 / 650	
<b>o / oBre</b>	196 / 252	236 / 294	261 / 325	302 / 377	332 / 423	IEC ⇒
<b>m / mBre</b>	16 / 22	42 / 48	47 / 50	52 / 55	58 / 62	
<b>n / nBre</b>	100 / 134	100 / 134	114 / 153	114 / 153	114 / 153	
<b>p / pBre</b>	100 / 89	100 / 89	114 / 108	114 / 108	114 / 108	



---

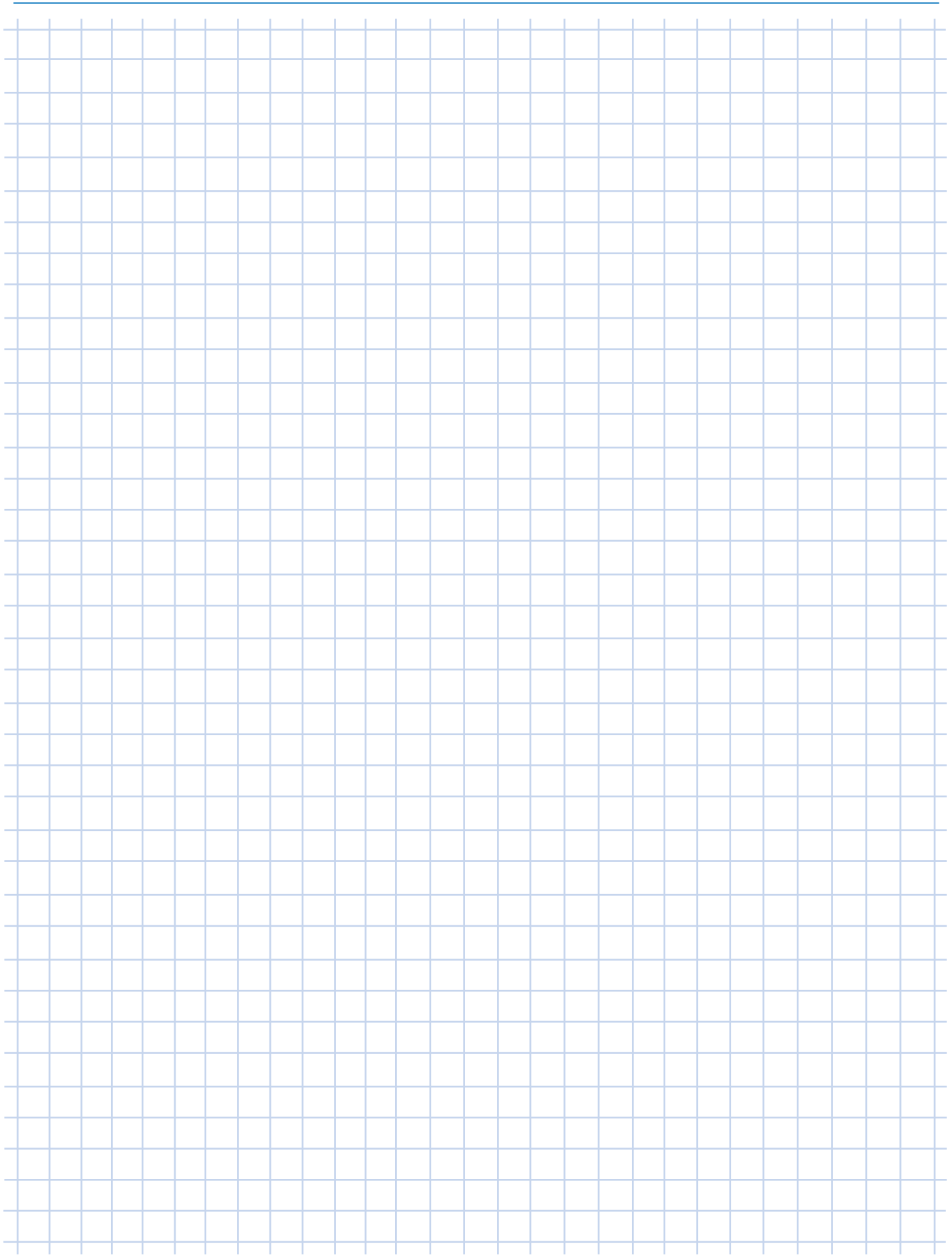

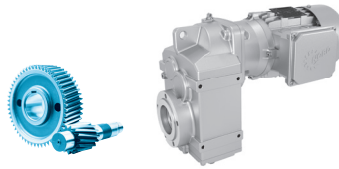

SK 0182.1 , SK 0282.1 VXZ (AXZ)

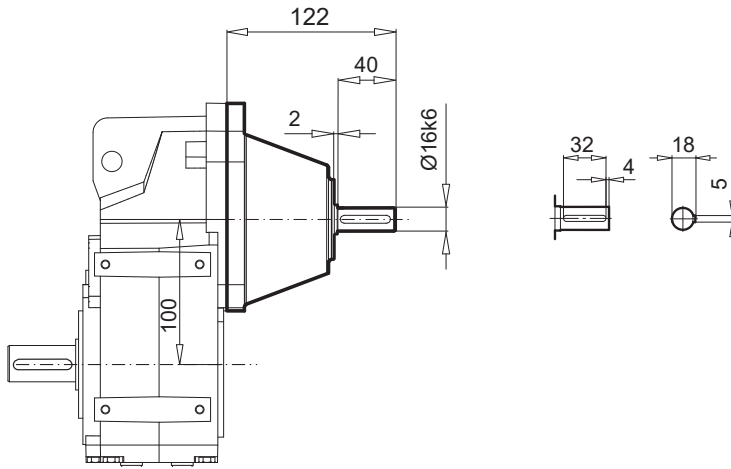

SK 0182.1 , SK 0282.1 VXF (AXF)

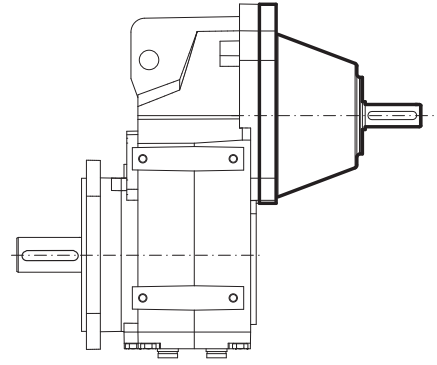

SK 1282.1 , SK 1382.1 VXZ (AXZ)

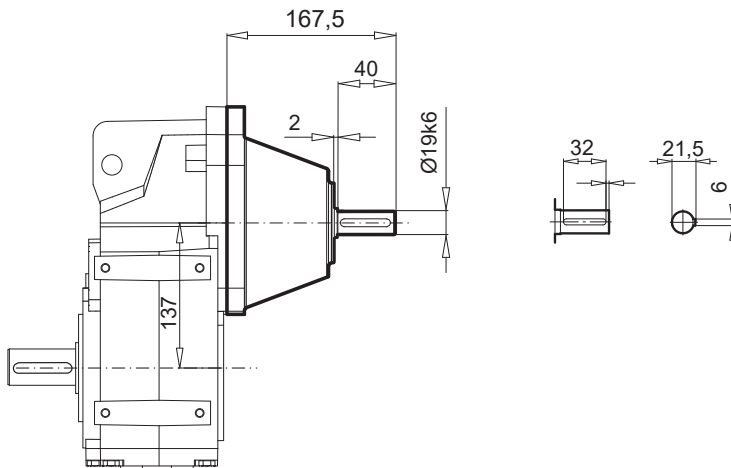

SK 1282.1 , SK 1382.1 VXF (AXF)

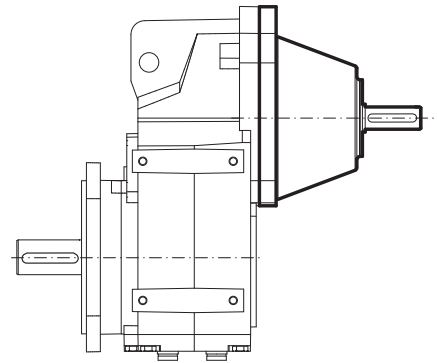

VL2/VL3

SK 1282.1 , SK 1382.1 VXF (AXF)

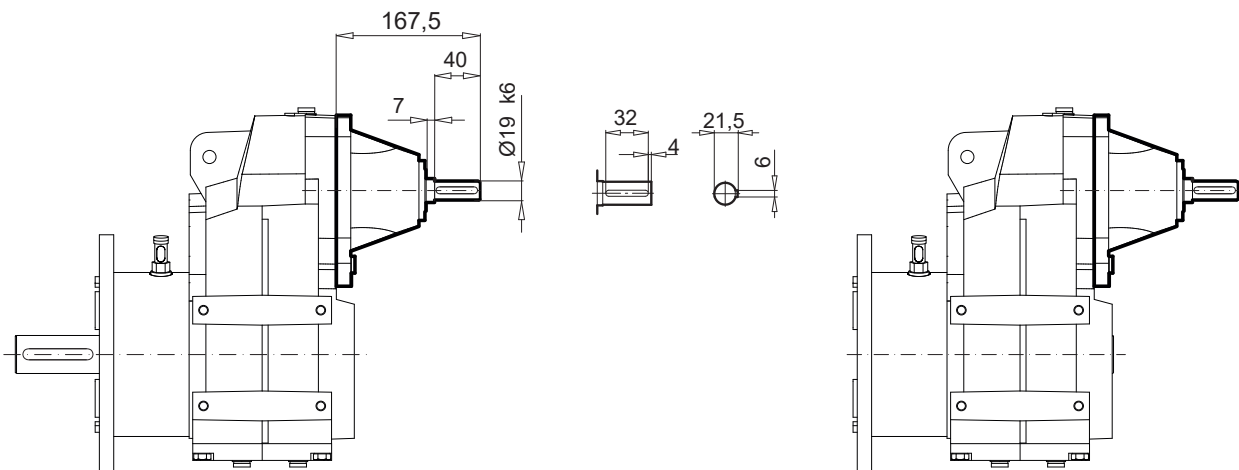

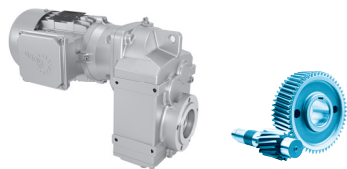

SK 0182.1 , SK 0282.1 VXZ (AXZ)  
SK 1282.1 , SK 1382.1 VXZ (AXZ)

VXF (AXF) - IEC 63 ... 90  
VXF (AXF) - IEC 63 ... 112

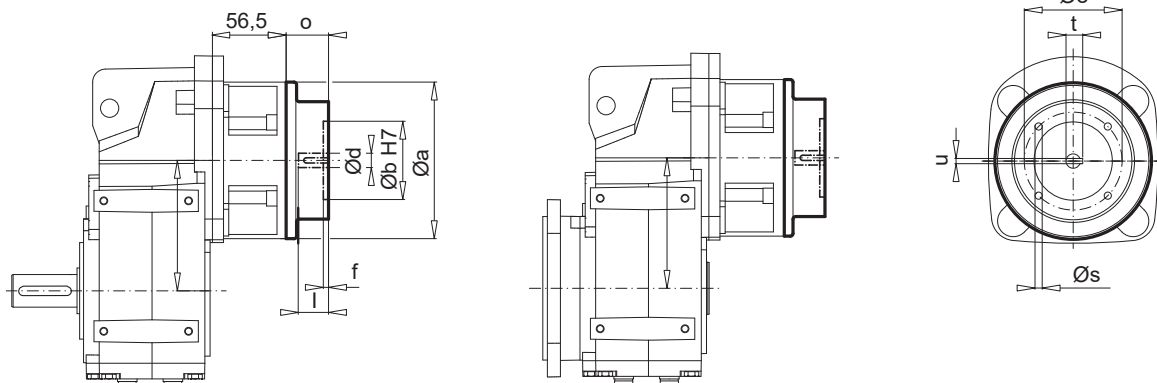

IEC	Ø a	Ø b	Ø e	f	Ø s	o	Ø d	l	t	u
IEC 63 - C90	120	60	75	4	5,5	32,5	11	23	12,8	4
IEC 63 - C120	120	80	100	4	6,6	32,5				
IEC 63 - A140	140	95	115	4	9	32,5				
IEC 71 - C105	120	70	85	4	7	32,5	14	30	16,3	5
IEC 71 - C140	140	95	115	4	9	32,5				
IEC 71 - A160	160	110	130	4	9	32,5				
IEC 80 - C120	120	80	100	4	6,6	32,5	19	40	21,8	6
IEC 80 - C160	160	110	130	4	9	32,5				
IEC 80 - A200	200	130	165	4	10	32,5				
IEC 90 - C140	140	95	115	4	9	45,5	24	50	27,3	8
IEC 90 - C160	160	110	130	4	9	45,5				
IEC 90 - A200	200	130	165	4	10	45,5				
IEC 100 - C160	160	110	130	5	9	36	28	60	31,3	8
IEC 100 - C200	200	130	165	5	9	36				
IEC 100 - A250	250	180	215	5	12	36				
IEC 112 - C160	160	110	130	5	9	36	28	60	31,3	8
IEC 112 - C200	200	130	165	5	9	36				
IEC 112 - A250	250	180	215	5	12	32,5				

### VL2/VL3

SK 1282.1 , SK 1382.1 VXF (AXF) VL2 / VL3 - IEC 63 ... 112

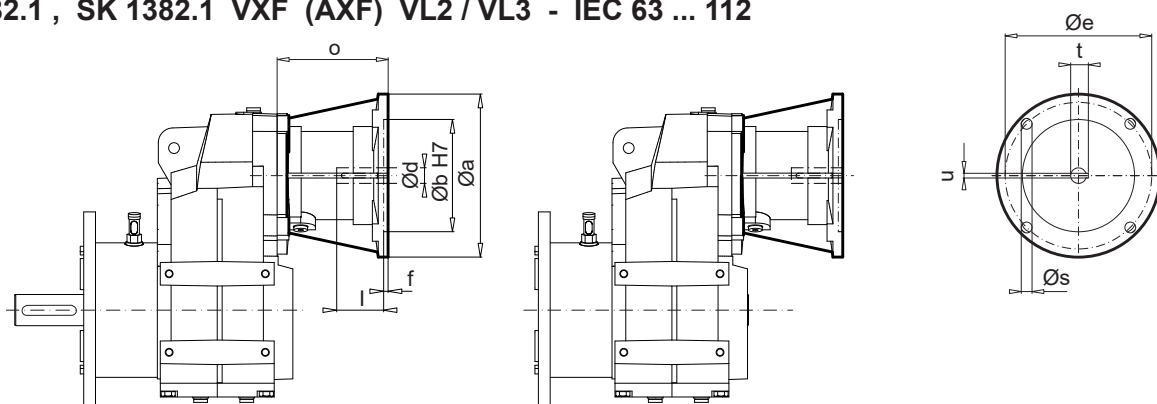

IEC	Ø a	Ø b	Ø e	f	Ø s	o	Ø d	l	t	u
IEC 63	140	95	115	4	8	84,5	11	23	12,8	4
IEC 71	160	110	130	4,5	8	88,5	14	30	16,3	5
IEC 80	200	130	165	4,5	10	106	19	40	21,8	6
IEC 90	200	130	165	4,5	10	106	24	50	27,3	8
IEC 100	250	180	215	5	12	125	28	60	31,3	8
IEC 112	250	180	215	5	12	125	28	60	31,3	8

---

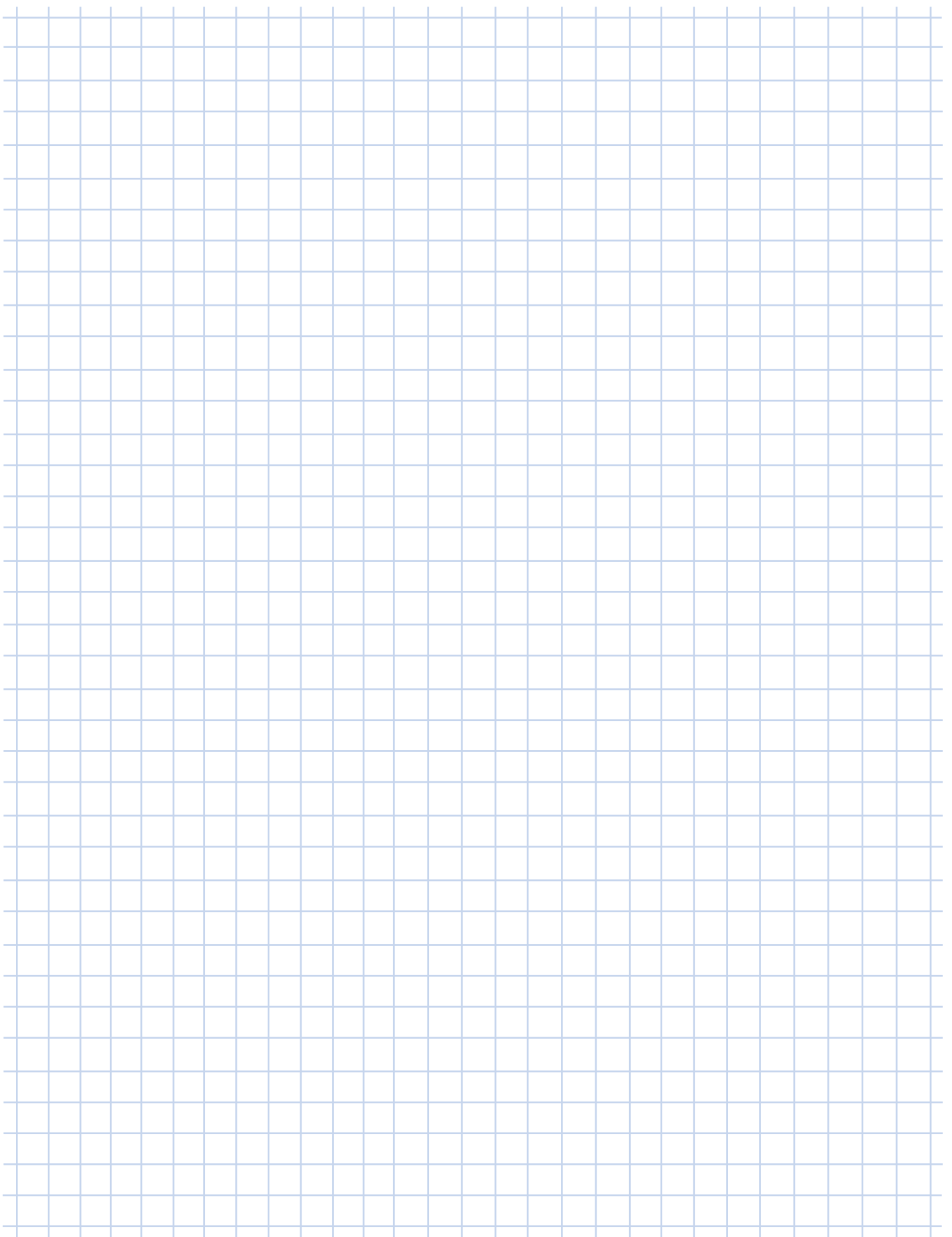

## G1000 Feste Drehzahlen BLOCK Gehäuse 50 / 60 Hz

- NORDBLOC.1 Stirnradgetriebemotoren
- Stirnradgetriebemotoren
- Flachgetriebemotoren
- Kegelradgetriebemotoren
- Stirnrad-Schneckengetriebemotoren

## G4014 Elektronische Verstellgetriebe

- NORDBLOC.1 Stirnradgetriebemotoren
- Stirnradgetriebemotoren
- Flachgetriebemotoren
- Kegelradgetriebemotoren
- Stirnrad-Schneckengetriebemotoren

## G1050 MAXXDRIVE® Industriegetriebe BLOCK Gehäuse 50 / 60 Hz

- Stirnradgetriebe
- Kegelstirnradgetriebe

## G1035 UNIVERSAL Schneckengetriebe

- SI und SMI

F3018\_E3000 Frequenzumrichter SK180E

F3020\_E3000 Frequenzumrichter SK200E

F3060\_E3000 NORDAC PRO  
Frequenzumrichter SK500P





**NORD DRIVESYSTEMS Group**

**Stammsitz und Technologiezentrum**  
in Bargteheide bei Hamburg

**Innovative Antriebslösungen**  
für mehr als 100 Industriezweige

**Mechanische Produkte**  
Flach-, Stirn-, Kegelrad- und Schneckengetriebe

**Elektrische Produkte**  
IE 2/IE3/IE4-Motoren

**Elektronische Produkte**  
zentrale und dezentrale Frequenzumrichter,  
Motorstarter, Feldverteiler

**7 technologisch führende Fertigungsstandorte**  
für alle Antriebskomponenten

**Tochtergesellschaften und Vertriebspartner**  
**in 98 Ländern auf 5 Kontinenten**  
bieten Vor-Ort-Bevorratung, Montagezentren,  
technische Unterstützung und Kundendienst.

**Mehr als 4.000 Mitarbeiter weltweit**  
schaffen kundenspezifische Lösungen.

[www.nord.com/locator](http://www.nord.com/locator)

(DE) Getriebebau NORD GmbH & Co. KG, Getriebebau-Nord-Str. 1, D-22941 Bargteheide  
Fon +49 (0) 4532 / 289 - 0 , Fax +49 (0) 4532 / 289 - 2253, [info@nord.com](mailto:info@nord.com)

(AT) Getriebebau NORD GmbH, A-4030 Linz, Deggendorfstrasse 8  
Fon +43 (0) 732 / 31 89 20, Fax +43 (0) 732 / 31 89 20 – 85, [info.at@nord.com](mailto:info.at@nord.com)

(CH) Getriebebau NORD AG, Bächigenstrasse 18, CH-9212 Arnegg  
Fon +41-71-388 99 11, Fax +41-71-388 99 15, [switzerland@nord.com](mailto:switzerland@nord.com)