

**MORE NORD APPLICATIONS
YOU MAY FIND INTERESTING:**

www.nord.com/references



DRIVE SYSTEMS FOR SMARTER CUTTING

CASE STUDY: TREIF



**Quick and precise
food cutting**



**Easy and comfortable
handling**



**Safe and reliable
operation**



**SK 540E frequency inverter
with PLC functionality**



**NORD UNIVERSAL
worm gear motor**

NORD DRIVESYSTEMS Group

- Family business from Bargteheide near Hamburg with 4,000 employees
- Drive solutions for more than 100 branches of industry
- 7 production locations worldwide
- Present in 98 countries on 5 continents
- More information: www.nord.com

Headquarters:

Getriebebau NORD GmbH & Co. KG
Getriebebau-Nord-Str. 1
22941 Bargteheide, Germany
T +49 4532 289 0, F +49 4532 289 2253
info@nord.com

Member of the NORD DRIVESYSTEMS Group

CS0001 Part No. 6065802 / 4117



Featuring a powerful microprocessor and integrated positioning functions, NORD's SK 540E frequency inverter allows for swift and precise slicing and dicing of various foodstuffs – with no need for an extra controller.



PROJECT CHALLENGE

Treif Maschinenbau GmbH manufactures machines and production equipment for cutting food into slices, strips, cubes, or other shapes. However, until recently, most of these machines still relied on conventional relays and circuit breakers instead of modern drive electronics that would feature much more exible functionality.

When NORD DRIVESYSTEMS introduced a novel type of frequency inverter featuring PLC capabilities, Treif found this to be an economically viable new control solution with enough built-in intelligence to allow for free programming of drive-related functions. As the “brain” of several new Treif machines, this inverter now ensures users enjoy improved functions, very comfortable handling, and optimized productivity.

Proven quality. In addition to the scope of functions and attractive

price, the tried and tested reliability of NORD drive solutions was an equally essential issue: Treif's many customers around the world are spread far across a range of countries, which includes remote and hard-to-service areas as well. Hence, the proven robustness and durability of the SK 500E inverter series was a crucial factor in choosing the innovative SK 540E for Treif machines. Previous positive hands-on experience with resilient NORD worm geared motors gave Treif even more con dence in this decision.

Conversion of a wide range of machines. The inverter-based new drive solution is to be rolled out across several segments of the Treif machine portfolio. Two machines mainly used for meat, sausage, and cheese slicing and dicing, CASEUS basic and FLEXON, are the first to pioneer this configuration.

APPLICATION SOLUTION

The central control unit of every machine is an intelligent SK 540E frequency inverter, whose integrated PLC operates with a cycle time of 10 milliseconds.

While it also handles the control buttons and status displays connected to it, the inverter's most notable task is to provide smart control for the machine's hydraulic system: a hydraulic ram ensures that pressure is always precisely adjusted for the piece of food in the machine in the way that achieves the best possible cutting results.

Easy to use and safe by design. The intelligent inverter used in Treif cutting machines comes with all proven basic characteristics of the SK 500E product family, comprising e.g.:

- sensorless current vector control,
- automatic parameter identification of the connected motor, and
- the “Safe Torque Off” safety function.

Highly versatile. Moreover, the SK 540E is designed to take control in complex and dynamic drive scenarios. Special features to this end include:

- a new universal encoder interface,
- asynchronous as well as synchronous motor control capability, and especially
- free programmability of drive-related functions according to the IEC 61131 standard.

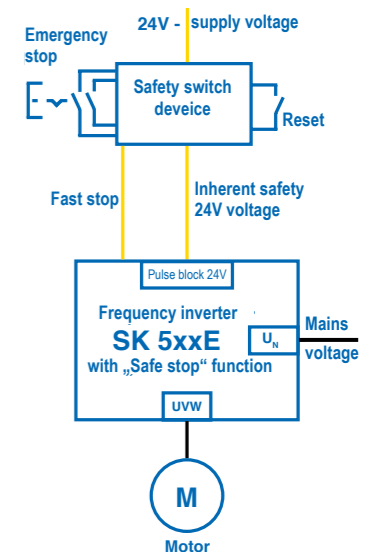

Accident prevention. “Safe pulse block” rules out a motor restart when a cover or door is opened.



FOOD INDUSTRY cutting machines



FREQUENCY INVERTERS SK 540E



GEARED MOTORS UNIVERSAL SI worm gear motors

FOCUS ON THE CUSTOMER



Based in Oberlahr in the West of Germany, Treif Maschinenbau GmbH is one of the world's leading manufacturers of food cutting machines and systems. Treif solutions are used in over 150 countries. A differentiated product range

addresses the needs of a wide range of users, from small businesses like butcher shops, to larger-scale catering establishments, to industrial food production and processing facilities.



FOCUS ON THE PROJECT

Allowing for free programming of drive-related functions according to the IEC 61131 standard, a frequency inverter for cutting machines ensures that foodstuffs can be sliced and diced:

- in more flexible ways than in circuit breaker based solutions,
- very precisely, quickly, and reliably,
- without any extra cost for an additional controller.

